

# Information

January 2003

Vol. 19, No. 1

# DISPLAY

SID

Official Monthly Publication of the Society for Information Display



## “Smart Panels” & PC Repartitioning

- **Rethinking the PC**
- **Combining High Definition with NTSC**
- **An Integrated GUI Controller Chip**
- **EuroDisplay 2002 Report**
- **A Visit to Tecdis**
- **Display Activity in Europe**

er.  
for p  
to the  
01970  
tors are  
classroc  
special r  
reprint c  
Display.  
2003 Soci

# Information DISPLAY

JANUARY 2003  
VOL. 19, NO. 1

Makers of display semiconductors are integrating more functions on each chip. Not only will these chips soon put all of a monitor's electronics inside the LCD module and turn them into "smart panels," but substantial parts of the host PC will wind up there too. When the display module is the system – or a large part of it – the relationship between module maker and OEM will never be the same again.



Philips

## Next Month in Information Display

### LCD Issue

- Reflections on Measurement Methods
- Managing the Cost of LCD Components
- LCDs: Price and Demand
- Bringing Backlights to the Fore
- SMAU 2002 Report

INFORMATION DISPLAY (ISSN 0362-0972) is published eleven times a year for the Society for Information Display by Palisades Convention Management, 411 Lafayette Street, 2nd Floor, New York, NY 10003; Leonard H. Klein, President and CEO. EDITORIAL AND BUSINESS OFFICES: Jay Morreale, Managing Editor, Palisades Convention Management, 411 Lafayette Street, 2nd Floor, New York, NY 10003; telephone 212/460-9700. Send manuscripts to the attention of the Editor, ID. Director of Sales: Joanne Morgenthal, Palisades Convention Management, 411 Lafayette Street, 2nd Floor, New York, NY 10003; 212/460-9700. SID HEADQUARTERS, for correspondence on subscriptions and membership: Society for Information Display, 610 S. 2nd Street, San Jose, CA 95112; telephone 408/977-1013, fax -1531. SUBSCRIPTIONS: Information Display is distributed without charge to those qualified and to SID members as a benefit of membership (annual dues \$75.00). Subscriptions to others: U.S. & Canada: \$55.00 one year, \$7.50 single copy; elsewhere: \$85.00 one year, \$7.50 single copy. PRINTED by Sheridan Printing Company, Alpha, NJ 08865. Third-class postage paid at Easton, PA. PERMISSIONS: Abstracting is permitted with credit to the source. Libraries are permitted to photocopy beyond the limits of the U.S. copyright law for private use of patrons, providing a fee of \$2.00 per article is paid to the Copyright Clearance Center, 21 Congress Street, Salem, MA 01970 (reference serial code 0362-0972/03/\$1.00 + \$0.00). Instructors are permitted to photocopy isolated articles for noncommercial classroom use without fee. This permission does not apply to any special reports or lists published in this magazine. For other copying, reprint or republication permission, write to Society for Information Display, 610 S. Second Street, San Jose, CA 95112. Copyright © 2003 Society for Information Display. All rights reserved.

## 2 Editorial

*A Visit to Tecdis*

*Kenneth I. Werner*

## 4 My Turn

*Sunny EuroDisplay 2002 Shows Depth of European Display Activity*

*Alain Doré*

## 12 Rethinking the PC

*Increasing integration in display electronics is prompting Philips Semiconductors and others to rethink and dramatically repartition the PC – which is making the display even more central to the system than it is now.*

*Roberto Simmarano*

## 16 Combining High Definition with NTSC: Part I

*An increasing number of TV viewers who do not have access to HD signals are enjoying HDTV image quality. Fortunately, modern video signal-processing chips can produce nearly HDTV quality with NTSC signals.*

*Gwyn Edwards*

## 20 Combining High Definition with NTSC: Part II

*The approaches described in Part I provide solutions to many video-conversion problems, but HD requires the addition of more-advanced techniques for high-quality imagery.*

*Gwyn Edwards*

## 24 Hard Solutions to Soft Problems

*A highly integrated chip provides GUI support for embedded systems with LCDs.*

*Jerry Shapiro*

## 28 EuroDisplay 2002 Was Filled with Surprises

*In a year when conference organizers everywhere were nervous about numbers, EuroDisplay 2002 exceeded attendance expectations – and added high quality, a much-appreciated location, and technical and non-technical surprises.*

*Ken Werner*

## 36 Baltimore, Hidden Gem of the East Coast, to Host SID 2003

*The Continental Congress met in Baltimore, and the international display community will meet there, too, from May 18 to 23, for the Society for Information Display's 34th International Symposium, Seminar, and Exhibition.*

*Ken Werner*

## 44 SID '03 Hotel Reservation Information

## 47 Sustaining Members

## 48 Backlight

*Call Me Quirky*

*David Lieberman*

## 48 Calendar of Display-Related Events

**For Industry News, New Products, Forthcoming Articles, and Complete, Continually Updated Conference Calendar, see [www.sid.org](http://www.sid.org).**



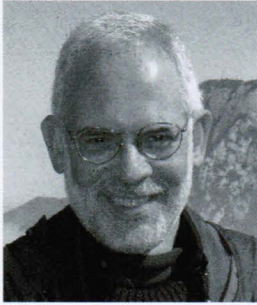

**A Visit to Tecdis**

It was too good an opportunity to pass up. I would be in Nice for EuroDisplay, and a quick drive into the French-speaking part of Italy would take me to the only remaining volume manufacturer of LCDs in Europe.

Well, a quick drive, perhaps – but not a short one. The extremely precise directions I received by e-mail from Tecdis Marketing and Sales Director Graziano

Scomazzon said that Chatillon, Italy, the home of Tecdis, was 410 km from Nice – “a minimum of 5 hours driving fast.” The Italian border was less than 30 km from Nice, and after another 100 km, much of it along the coast and through mountain tunnels, I turned north on the A26 autostrada. And I drove fast, as instructed, through way points with names like Gravellona and Casale Nord.

I became excited when the snow-covered Alps appeared on the horizon – I had never seen the Alps before – and surprised when the directions took me up into the Alps and the Valle d’Aosta. And there was Chatillon: a beautiful and surprising location for Europe’s largest LCD manufacturer.

I was received with great courtesy by Scomazzon, and then by President and General Manager Ettore Morezzi, General Manager Piergorgio Brunod, and many of their colleagues. The conversation was frank and friendly. I was told that Tecdis had been established in 1985 as a joint venture between Olivetti and Seiko, with the idea of using Seiko technology to make displays for Olivetti’s office products. Morezzi came in at that time from the Olivetti side of the marriage. The plant opened in 1990 and received ISO 9002 certification in 1993.

*continued on page 42*

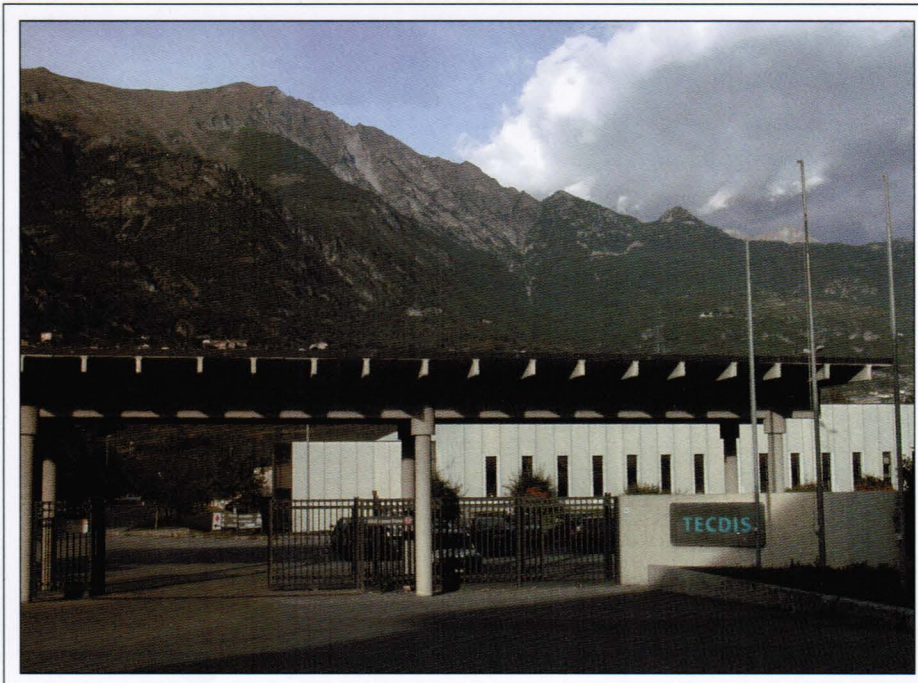

Ken Werner

*The entrance to Tecdis, Europe’s only remaining volume LCD-manufacturing company, is not unusual except for the Italian Alps rising behind the plant.*

**Editor:** Kenneth I. Werner  
**Managing Editor:** Jay Morreale  
**Administrative Editor:** Dian Mecca  
**Administrative Assistant:** Ralph Nadell  
**Contributing Editors:** David Lieberman, Bryan Norris, Alfred Poor,  
**Advertising Manager:** Jay Morreale  
**Sales Manager:** Joanne Morgenthal

**Regional Associate Editors**

- Allan Kmetz (**Americas**)  
*Agere Systems  
 Berkeley Heights, New Jersey*
- Shigeo Mikoshiba (**Asia**)  
*University of Electro-Communications  
 Tokyo, Japan*
- Alan Mosley (**Europe**)  
*Central Research Laboratories  
 Hayes, Middlesex, U.K.*

**Advisory Editors**

- Carl Machover  
*Machover Associates  
 White Plains, New York*
- Alan Sobel  
*Consultant  
 Evanston, Illinois*
- Webster E. Howard  
*eMagin Corp.  
 Hopewell Junction, New York*
- Ernst Lueder  
*University of Stuttgart  
 Stuttgart Germany*
- Sungkyoo Lim  
*Information Display Research Center  
 Choongnam, Korea*

The opinions expressed in editorials, columns, and feature articles do not necessarily reflect the opinions of the editor or publisher of *Information Display Magazine*, nor do they necessarily reflect the position of the Society for Information Display.





## Sunny EuroDisplay 2002 Shows Depth of European Display Activity

by Alain Doré

The triennial EuroDisplay Conference is a remarkable opportunity for all of us European engineers and scientists to publicize our display activity. First of all, I want to thank all the authors (more than 850) for their contributions and all the participants (more than 620) and visitors for their presence in Nice.

During the last decade, it was natural for us to look toward the Far East to discover the main trends of display manufacturing and toward the Far West to anticipate the development of new image-processing concepts and new electronic chips dedicated to display addressing.

But, if the sun is always observed to rise in the East and set in the West regardless of where one may be on our rotating Earth, all other observations are subject to some relativity. In each of our regions – the Americas, Asia, and Europe – we observe contrasting types of display activity, but it would be far too simple to say that manufacturing has become the exclusive prerogative of the Asian industry, or that information processing cannot be developed without an American partner.

We maintain that the major European industrial activities are led by automotive, transportation, telecom, and chemical applications. And up to now, we have also tried to emphasize cultural rather than commercial quality in TV broadcasting.

If fewer and fewer TV sets and other displays are manufactured in Europe, the impact of European display activity continues to be remarkable and important. Here are some examples:

- MERCK KgA is the world leader in supplying liquid-crystal materials.
- Saint-Gobain Display Glass is now a well-known supplier of glass for PDPs and FEDs.
- Unaxis Balzers AG installs equipment for display manufacturers all over the world.
- ELDIM is a leader in display contrast measurement.
- Philips and Thomson are leading worldwide purveyors of TV sets for consumers and monitors and image-processing products.
- Electroluminescent displays are manufactured by Planar in Finland.
- LCDs are made by Tecdis in Italy and by Optrex in Germany for harsh-environment applications.
- VDO-Optrex, Borg-Valéo, Magneti-Marelli, and Johnson Control Automotive Electronics (ex-Sagem) are suppliers of electronic dashboards for worldwide automotive manufacturers.
- THALES Avionics designs and manufactures TFT-LCDs for cockpit displays that are sold to Airbus and Boeing.
- Nokia, Siemens, Philips, Ericson, Alcatel, and Sagem are using millions of small displays for mobile phones and other handheld electronic products.
- ASULAB designs and manufactures thin LCDs that are integrated into luxurious watch dials.
- AEG, Siemens, and Mitron equip buses, tramways, trains, train stations and bus stops, and airport passenger information systems with LCD and LED information boards.

*continued on page 46*

### SID Executive Committee

President: A. Kmetz  
 President-Elect: S. Mikoshiba  
 Regional VP, Americas: M. Anandan  
 Regional VP, Asia: M. H. Oh  
 Regional VP, Europe: J-P. Budin  
 Treasurer: R. Seery  
 Secretary: P. Drzaic  
 Past President: A. Silzars

### Directors

Bay Area: N. Balram  
 Beijing: B. P. Wang  
 Belarus: A. Smirnov  
 Canada: T. C. Schmidt  
 Dayton: D. G. Hopper  
 Delaware Valley: J. W. Parker III  
 Detroit: R. L. Donofrio  
 France: M. Hareng  
 Hong Kong: H. Leung  
 India: K. R. Sarma  
 Japan: M. Maeda  
 Korea: M. K. Han  
 Los Angeles: P. C. Baron  
 Mid-Atlantic: A. Ghosh  
 Mid-Europe: J. Kimmel  
 Minneapolis/St. Paul: H. V. Holec  
 New England: W. A. Hamilton  
 Pacific Northwest: J. A. Rupp  
 Russia: V. V. Belyaev  
 San Diego: T. Iki  
 Singapore/Malaysia: B. A. Ghani  
 Southwest: P. A. Smith  
 Taipei: F-C. F. Luo  
 Texas: Z. Yaniv  
 U.K. & Ireland: A. Mosley  
 Ukraine: V. Sorokin

### Committee Chairs

Academic: H. Uchiike  
 Archives/Historian: D. Dumont  
 Bylaws: E. Lueder  
 Chapter Formation: B. Needham  
 Communications: H. Hoffman  
 Convention: P. M. Heyman  
 Definitions & Standards: D. Hopper  
 Honors & Awards: L. F. Weber  
 Long-Range Planning: T. Iki  
 Membership: R. Kessler  
 Nominations: A. Silzars  
 Publications: E. Stupp

### Chapter Chairs

Bay Area: M. F. Flynn  
 Beijing: J-L. Zhu  
 Belarus: S. Yakovenko  
 Canada: A. Kitai  
 Dayton: J. C. Byrd  
 Delaware Valley: S. Kalatucka, Jr.  
 Detroit: S. Pala  
 France: R. Meyer  
 Hong Kong: H. S. Kwok  
 India: S. Kaura  
 Japan: Y. Shimodaira  
 Korea: L. S. Park  
 Los Angeles: M. L. Kesselman  
 Mid-Atlantic: V. R. Capozzi  
 Mid-Europe: N. Fruehauf  
 Minneapolis/St. Paul: E. L. Tomczak  
 New England: S. P. Atwood  
 Pacific Northwest: T. Voutsas  
 Russia: I. N. Kompanets  
 San Diego: A. R. Wilson  
 Singapore/Malaysia: X. Sun  
 Southwest: D. S. Lowe  
 Taipei: H.-P. D. Shieh  
 Texas: R. L. Fink  
 U.K. & Ireland: J. A. Raines  
 Ukraine: V. G. Sorokin

### Office Administration

Executive Director: Dee Dumont  
 Data Manager: Jenny Needham

### Society for Information Display

610 S. 2nd Street  
 San Jose, CA 95112  
 408/977-1013, fax -1531  
 e-mail: office@sid.org  
 http://www.sid.org



## Rethinking the PC

*Increasing integration in display electronics is prompting Philips Semiconductors and others to rethink and dramatically repartition the PC – which is making the display even more central to the system than it is now.*

by Roberto Simmarano

**T**HE ORIGINAL IBM PC came in a case that was  $16 \times 19.5 \times 5$  in. and weighed 27 lbs. even without any hard-drive storage. And those dimensions did not include any display. It is no surprise that advances in all aspects of computer technology have resulted in systems that are more powerful, smaller, lighter, and far less expensive than that first PC nearly 22 years ago. But what does the future hold? As advances continue, what can we expect from future designs?

Some improvements are strikingly apparent. The flat and thin displays made possible by liquid-crystal-display (LCD) technology have made truly portable computers and pocket devices possible. Improvements in optical and magnetic storage have resulted in rewritable DVDs that hold many gigabytes and tiny 2-in. hard-disc drives that hold tens of gigabytes. The miniaturization of integrated circuitry has produced inexpensive central processing units (CPUs) that outperform the supercomputers of recent history, and entire libraries can be stored on a palm full of memory chips.

Still, it is the integration of these and other advances that propels the computer industry. Buyers rushed to embrace the newest iMac, with its LCD hanging from an articulated arm which is mounted on an improbably small dome that contains the computer (Fig. 1).

A number of enabling technologies also have the potential to reshape how we think

*Roberto Simmarano is Technical Program Manager at Philips Semiconductors, 1130 Ringwood Court, San Jose, CA 95131; e-mail: roberto.simmarano@philips.com.*

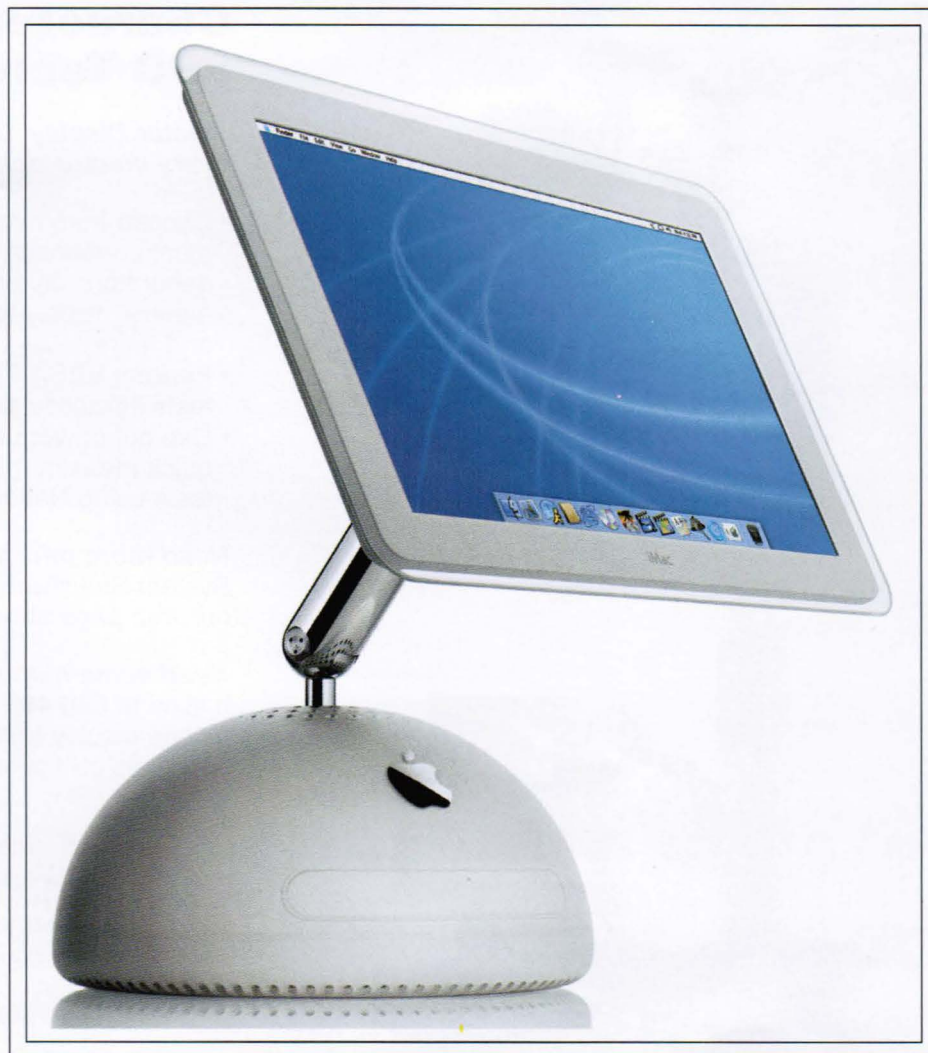

Apple Computer

**Fig. 1:** The now-familiar Apple iMac has sparked interest in innovative form factors for personal computers.



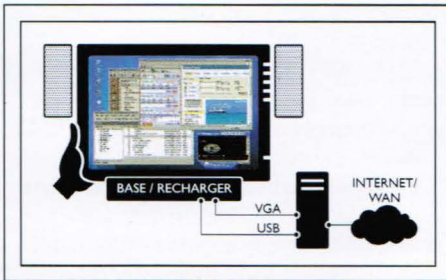

**Fig. 2:** Microsoft's Mira is based on multiple technologies, including secure 802.11, instant-on, and accelerated graphics, all delivered in Windows CE.NET.

about using computers. Wireless connectivity – including 802.11b, 802.11a, and Bluetooth – has helped cut the cable connection between the computer and other resources such as networks and peripherals. High-speed cabled connections such as USB 2.0 and IEEE 1394/FireWire make it practical to move large amounts of data between separate devices. And improved battery technology and power-management facilities within operating systems have extended our expectations for portable devices.

Microsoft has two initiatives with different objectives under way that take advantage of many of these features. The Tablet PC re-defines notebook computing, making the keyboard optional thanks to a touch-sensitive display screen. And the Mira design that was announced at the Consumer Electronics Show in January 2002 uses wireless connectivity to let the user detach the display from the computer and still interact with the system while moving around (Fig. 2).

### Saving Space in the Workplace

These changes can lead to more than just improved aesthetics. A popular way to cut a facility's operational costs is to make each employee's office space more ergonomically effective. The typical combination of a CRT-based monitor and tower CPU case take up an inordinate amount of space, yet the user must have ready access to both components. Although it would be nice to hide the tower away, the user still has to reach it to load and unload removable media and plug in peripherals such as a personal digital assistant (PDA). Flat-panel-display (FPD) monitors give back some desk space, but do not reduce the size of the tower CPU case.

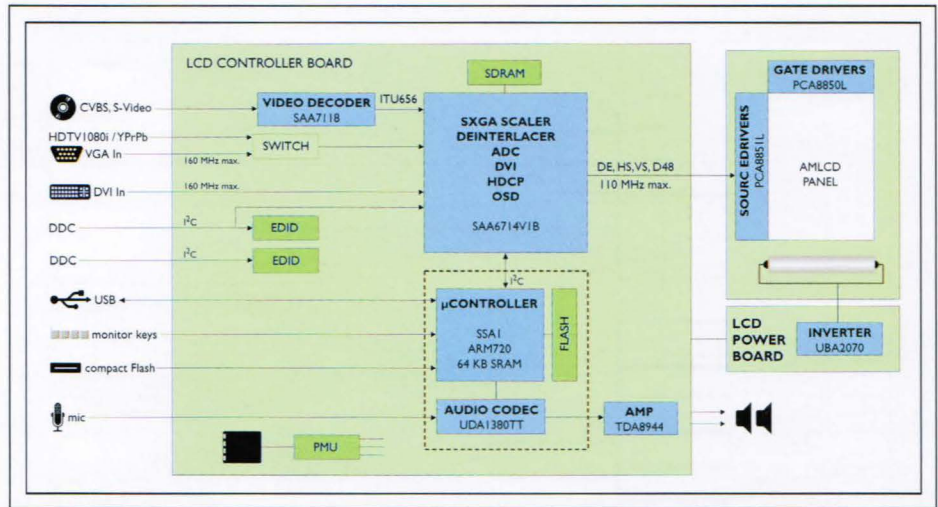
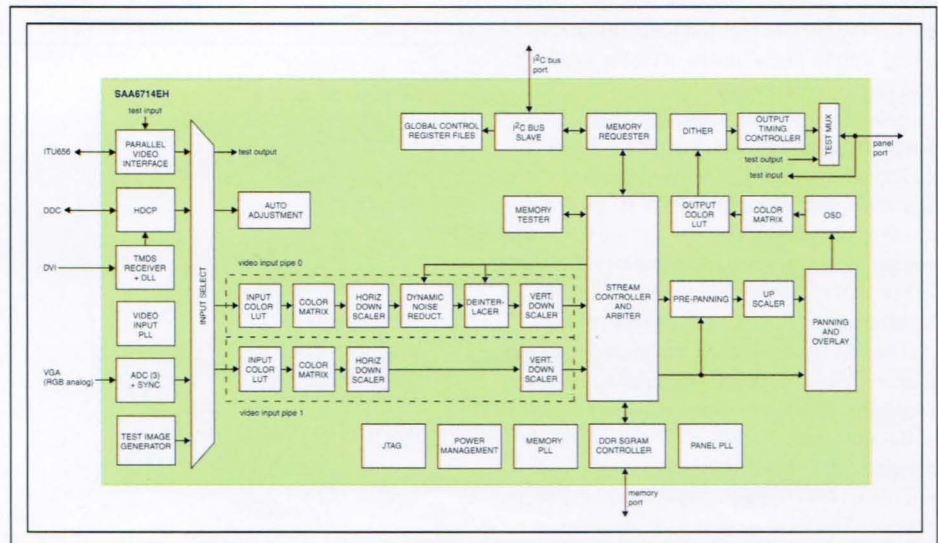

**Fig. 3:** A reference design from Philips Semiconductors demonstrates how most of a display's controlling circuitry can be provided by just two highly integrated chips.

The way to break out of the box is to “enhance” the monitor. Early changes in this direction added audio ports for headsets and microphones, as well as USB 2.0 hubs to make it easy to plug in devices. A logical extension of this idea would be to add removable-media storage drives, such as floppy-disc, CD, and DVD drives, to the display housing. The CPU case can then be used for connections that do not require frequent access, and it can be hidden out of sight close to power and local-area-network (LAN) sock-

ets. The display – and keyboard and mouse – could then be connected to the CPU case by a single display cable and a USB cable (some projector companies already combine these two functions in a single cable and connector).

Repartitioning the hardware functions in this way makes upgrades easier. The CPU case can be replaced without disturbing the display and other components. As a result, the desk unit with the display and peripherals could conceivably be used unchanged through several processor generations, further adding



**Fig. 4:** The SAA6714 is one of the two chips in the reference design; it handles everything from on-screen display to scaling.



# displays and systems

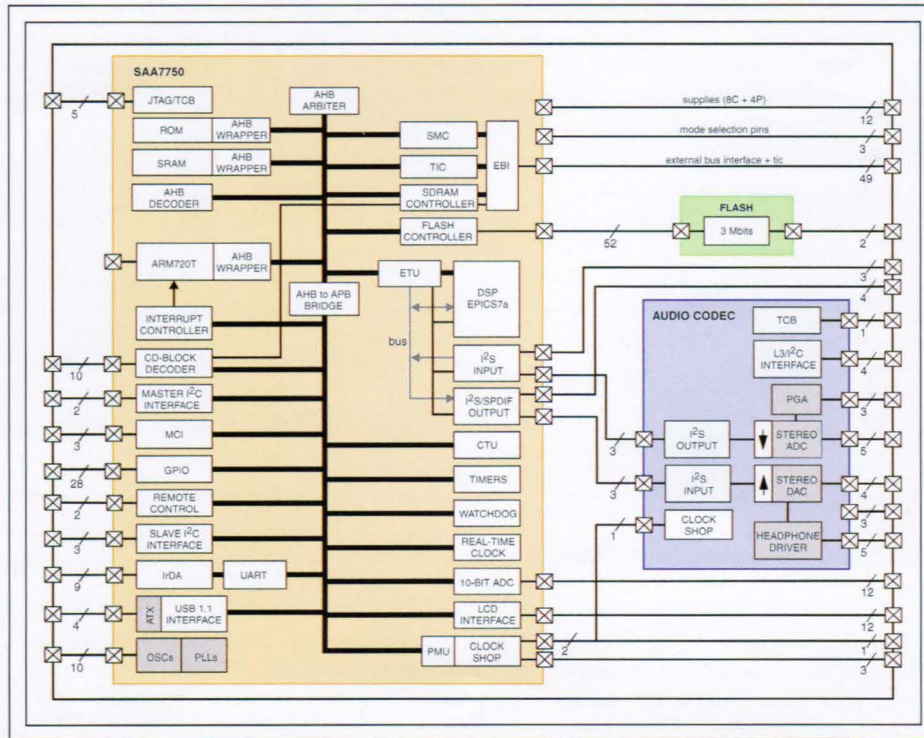

**Fig. 5:** The second chip in the design is the SAA7750; it incorporates both a microprocessor and an audio codec, as well as flash memory to allow field upgrades to the system software.

to savings in serviceability and total cost of ownership. Current examples of desktop PCs that are moving in this direction are Gateway's Profile, H-P's e-PC, and Dell's Optiplex models. The e-PCs have an FPD monitor and a smaller tower, and the Profile moves the peripherals and CPU into a relatively thin FPD enclosure, with the keyboard and mouse separate.

### Implications for the Supply Chain

Changes in computer design in general – and display design in particular – will lead to changes in the relationships among chip companies, panel makers, and monitor integrators.

Presently, monitor integrators purchase integrated circuits (ICs) from chip makers and panels from panel suppliers and then put them together. Previous generations of panel-controller ICs were fabricated using medium-scale integration (MSI), with only analog-to-digital (A/D) conversion and a digital video interface (DVI) on the chip. The panel timing control (TCON) function was provided on a separate chip, which was part of the panel that came from the display OEM. In what has been referred to as "smart integration," newer

LCD-controller chips now integrate the TCON, which reduces OEM assembly costs.

Furthermore, new panel controllers with reduced-swing differential signaling (RSDS) interfaces between the control board and panel reduce space, power, and shielding requirements for electromagnetic interference (EMI).

Shortly, the microcontroller unit for the LCD controller will also move onto the same chip, and an array of alternative low-EMI interfaces – including mini low-voltage differential signaling (miniLVDS) – will be available. Further board-level integration will come from combining panel-lighting ICs with the other power-function ICs on a single board.

To enable thinner monitors, panel manufacturers already are mounting the LCD-controller and backlight-supply chips on the back of the panel itself, a concept known as "smart panel." Chip-on-glass (COG) assembly offers the potential for even thinner panels when these controller chips are fastened directly to the display's glass substrate without intermediate packaging. Advances in low-temperature polysilicon (LTPS) and continuous-grain silicon (CGS) could go a big step further and allow at least some of these functions to be fabricated on the display substrate itself. As a result, the traditional role of the monitor integrator could change when the panel manufacturer builds all the semiconductors into the FPD module that were once

**Table 1: Power Budgets (W) for Detachable Display (When Detached)**

	Photo Album Application	Boombox Application	Full Mira Monitor
15-in. Display			
Display drivers	4	4	4
Backlight	20	20	20
LCD controller (SAA6714)	1.0	1.0 (2.4 V, 3.3 V)	1.0
Multimedia (SAA7750 + Amp)	0.2	1.2 (1.8 V, 2.4 V, 3.3 V)	0.1
Memory (2M × 32 DR)	0.7	0.7 (2.4 V)	0.7
CPU memory	0.05	0.05 (2.4 V)	2.0 (32 MB min)
WLAN (802.11b)			
Receive	N/A	N/A	0.5
Transmit	N/A	N/A	1.5
<b>Total Power</b>	<b>26</b>	<b>27</b>	<b>30</b>

Note: Assuming a lithium-ion battery with 60 W-hour capacity, this would require a battery with dimensions totaling 125 cc and an OEM cost of approximately \$30.





ViewSonic

**Fig. 6:** ViewSonic's airpanel™ wireless smart display is one of the first implementations of the Mira concept, which features the "instant-on" Microsoft Windows CE.NET operating system and full-screen viewing combined with wireless connection of the display and control panel to the system unit.

added by the monitor integrator. This will lower production costs for all involved, but may have important implications for end-product differentiation and may shift the location where the profits are made.

### Practical Considerations

The key to accelerating this increased integration of display panels and the supporting circuitry is the development of reference designs. Philips, for one, has demonstrated how its chips can be applied to real-world designs.

A Philips Semiconductors reference design for a removable FPD with multimedia includes a block diagram indicating the system's major components and functions (Fig. 3). Most of the components are standard ICs, but the display function and LCD control are executed by an SXGA LCD microcontroller and a multimedia microcontroller from ARM, Ltd.

The SXGA microcontroller – Philips Semiconductors' SAA6714 – is a single-chip

LCD-controller IC that incorporates analog VGA, parallel YUV, and DVI 1.0-compliant digital video inputs and SXGA LCD outputs (Fig. 4). Features include independent horizontal and vertical up- and down-scaling, enhanced text scaling, and sophisticated color management, including 10-bit gamma correction. An on-screen-display (OSD) generator provides both a fixed font in ROM and a downloadable font with a programmable character size and bit-mapped OSD graphics. The SAA6714 chip also incorporates multiple-filter dynamic-noise reduction (DNR), which reduces the visually perceived noise in video images while maintaining image contrast. It requires just a single-chip external double-data-rate SDRAM, which allows arbitrary frame-rate conversion. The SAA6714 chip can handle interlaced and non-interlaced video inputs. Its panel timing interface drives the panel's row and column drivers directly.

The other major chip in the reference design – the SAA7750 ASSP – handles both audio processing and picture decompression

(Fig. 5). It embeds a 72-MHz ARM720T 32-bit reduced-instruction-set computer (RISC) processor core plus a 24-bit Epics7A DSP audio co-processor DSP core. There is also a USB 1.1-compliant interface for downloading data along with flash-card support and a CD data and audio interface. The chip also includes an embedded 3-Mbit (384 kbyte) flash-memory array for field upgradability.

The reference design calls for undocking the display from the monitor base, which means that battery power requirements are also a consideration. Table 1 summarizes the semiconductor power budget for three applications. In all three instances, the heaviest load is the panel backlight – about 45 W.

### The Future Is Thin

As LCDs overtake cathode-ray tubes (CRTs) in the PC-peripheral marketplace, manufacturers are thinking about repartitioning the PC by using the display as the system component that provides the user with an interface not just for images, but for other media as well. In the office, this has multiple benefits. It allows processor upgrades without requiring the purchase of a whole new system; it improves user ergonomics by placing peripherals at the user's fingertips; and it allows the CPU case to be tucked out of the way. In consumer applications, it offers new opportunities for product enhancements all the way from turning the monitor into a simple portable photo album for digital pictures to Microsoft's Mira concept – which has now been renamed "the Microsoft Windows Powered Smart Display" (Fig. 6).

Such enhancements can be achieved at a modest cost premium relative to bare-bones FPD monitors. As the trend towards higher integration advances, product designers will be free to explore the functional relationships among the various components, which will lead to new form factors. This integration will further reduce development and production costs, making smarter displays containing more features a likely part of the computing landscape of the future. ■

Please send new product releases or news items to Information Display, c/o Palisades Convention Management, 411 Lafayette Street, 2nd Floor, New York, NY 10003.



# Combining High Definition with NTSC: Part I

*An increasing number of TV viewers who do not have access to HD signals are enjoying HDTV image quality. Fortunately, modern video signal-processing chips can produce nearly HDTV quality with NTSC signals.*

by Gwyn Edwards

**M**OVING more slowly than originally intended, the digital TV revolution is advancing at an evolutionary rather than revolutionary pace. The problem is classic chicken-and-egg: the consumer does not want to spend two to four times as much money for a high-definition (HD) capable TV because there is negligible content to watch in HD, while the broadcaster does not want to invest in HD broadcasting equipment because there is a very small audience.

To circumvent this problem, a variety of mandates have been suggested, such as requiring all large-screen TVs – defined as 36 in. and larger – to be fitted with HD tuner/decoders by January 1, 2005. Smaller TVs will follow suit, so that all TVs on the market will be true HDTVs by the end of 2006, thus eliminating the broadcasters' "excuse" for not investing (for more information, see [http://www.fcc.gov/commissioners/powell/mkp\\_proposal\\_to\\_speed\\_dtv\\_transition.pdf](http://www.fcc.gov/commissioners/powell/mkp_proposal_to_speed_dtv_transition.pdf)). Of course, given that the average lifespan of a TV set is about 10 years, there will still be TV sets in use that are not HD-capable for a long time after that.

## What About All That NTSC Content?

Scanning and pixelated devices are the two

*Gwyn Edwards has worked in the field of video processing since joining Faroudja Laboratories, now a division of Genesis Microchip, Inc., 2150 Gold Street, Alviso, CA 95002; telephone 408/934-4538, fax 408/262-6365; e-mail: [gwyne@genesis-microchip.com](mailto:gwyne@genesis-microchip.com).*

basic types of displays. The first type is represented by the humble CRT that has been the work-horse of the TV industry from its beginnings. The CRT can be used to display either interlaced or progressively scanned images with equal ease. An interlaced signal is one in which the frame is split into two fields, the first consisting of the odd lines of the frame (the odd field) and the second consisting of the even lines (the even field). They are transmitted and displayed sequentially, whereas for a progressively scanned image there is only one field, and all the lines are displayed in every frame.

The CRT's main drawback is that, in order to make the TV set compact and inexpensive,

it is necessary to use a single scan rate for all applications. In the past, this was no problem because there was only one TV standard in any given geographical region. In the U.S., the standard was 525-line interlaced NTSC (525i) with a scan rate of 15.734 kHz, and the CRT displays designed for it were ideal for the purpose and inexpensive. The NTSC format is now referred to as standard-definition (SD) TV.

The second display type is represented by newer technologies such as liquid-crystal displays (LCDs), Digital Light Processing™ (DLP™), and plasma-display panels (PDPs). Unlike CRTs, they present no cost or size



**Fig. 1:** Feathering, a serious artifact, results from the attempt to perform de-interlacing by simply weaving odd and even fields when the image is moving.

Genesis Microchip, Inc.

penalty for scanning at multiple rates, but the disadvantage is that they are all intrinsically progressively scanned displays. NTSC and other interlaced images must therefore first be de-interlaced before they can be displayed. De-interlacing is the process of converting the interlaced signal into its progressively scanned equivalent, in which all the lines are transmitted and displayed sequentially in one field.

Although an increasing amount of broadcast material is now being recorded in HD, even when all broadcasting becomes digital – at some time after 2006 – there will still be a lot of legacy material recorded in NTSC that the broadcasters will want to show. Consequently, these programs will need to be upconverted to one of the HD (1080i, 720p) or enhanced-definition (ED) (480p) standards, either at the transmitter or at the receiver, regardless of the display type used.

HD CRT displays will usually be designed to operate at the 1080i line rate (33.75 kHz), so it will be necessary to upconvert 15.734-kHz NTSC signals to this higher rate and show them as 1080i (or 540p, which has the same scan rate). NTSC can be directly upconverted from 525i to 1080i using intra-field spatial interpolation, but the result will be a much “softer” picture than one from a system that first adaptively de-interlaces the image, then spatially upconverts it to 1080p, and then re-interlaces it to 1080i. (Note that there is a discrepancy between the terms “525i” and “1080i.” In a one-to-one comparison, the latter should be called “1125i” because the “525” refers to the total number of lines per frame, while the “1080” refers to the number of active, or visible, lines. A frame with 1080 active lines has a total of 1125 lines.) Pixelated displays always have a fixed number of pixels per frame, so in these cases it will be necessary to not only de-interlace the NTSC signals, but also to upconvert them to the native resolution of the display itself.

### Improving NTSC Content for HD Displays

There are just two basic methods of de-interlacing. Either the lines in the odd and even fields can be added together (field weaving, or merging) or the missing lines in each field can be generated by interpolation without any reference to the other field (intra-field spatial interpolation, also known in the PC industry as “bobbing”). In practice, there are many

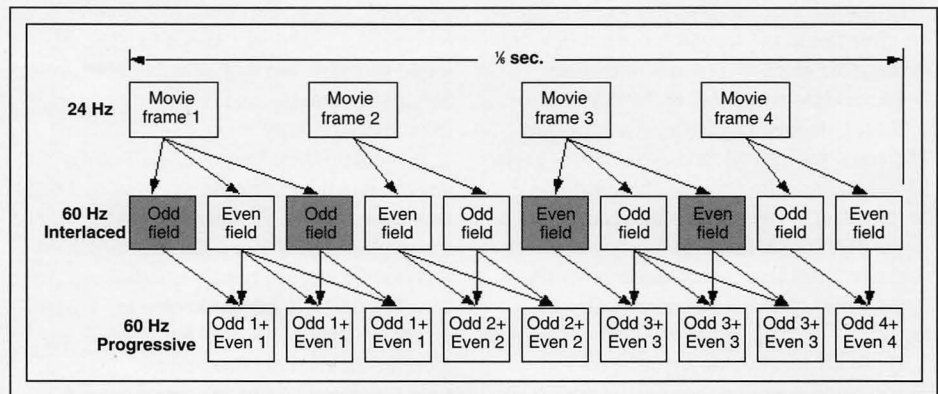

**Fig. 2:** Images that originated on film and were then converted to video using a teleciné machine are very common. In NTSC, the teleciné process converts the 24-frames/sec film into 60-fields/sec interlaced video using a process known as “3:2 pull-down.” A process called “reverse 3:2 pull-down” is used for de-interlacing.

ways of adaptively combining these two methods, but there are still only these two basic methods.

### Using Adaptivity to Optimize De-interlacing

The two basic methods of de-interlacing are each perfectly suited to one type of image. Field weaving, or merging, is perfectly adapted to still images because it uses all the information available and thus generates the best possible image. No motion artifacts will be generated because, by definition, there will be no motion: it is a still image. Using spatial interpolation on a still image would throw away half of the vertical resolution, since only half the lines are available to generate the other half.

When the image is moving, however, any attempt to weave the fields will result in very bad motion artifacts because the images in each field are separated in time by 1/60 of a second in NTSC. For example, a car moving at 60 mph will move by almost 1.5 ft. in this time, so that vertical edges in the odd and even fields will be separated by this distance. These artifacts are commonly known as “feathering” because the vertical edges in the image take on the appearance of feathers (Fig. 1).

The solution to this problem is to switch to spatial interpolation when the image is moving, thus eliminating the motion artifacts at the expense of the vertical resolution. This turns out to be a good tradeoff because the eye is much less sensitive to resolution in the pres-

ence of motion than it is when the image is still. Genesis Microchip, Inc., calls its technology for adapting between weaving and interpolation “Motion Adaptive De-interlacing™” (MADi™).

The major differences between the various algorithms used by vendors of de-interlacing chips lie in the way weaving and interpolation are blended, and the sophistication of the motion-detection algorithms used. The simplest method is to look for motion on a field-by-field basis and select either field weaving or spatial interpolation. Naturally, this method is inferior to algorithms that operate on a pixel-by-pixel basis because most images contain a mix of still and moving regions. However, operating on a pixel-by-pixel basis introduces new problems, including the fact that motion detection at this level is much more difficult and less robust than when it is done on a whole field. In addition, we must confront the problem of what to do at the boundary of the still and moving regions because we never have hard, *i.e.*, single-pixel, boundaries as a result of the limited signal bandwidth.

### Film-Mode Detection (Reverse 3:2 Pull-Down)

Images that originated on film and were then converted to video using a teleciné machine are very common, not only in TV but also in videotape and DVDs. In NTSC, the teleciné process converts the 24-frames/sec film into 60-fields/sec video using a process known as “3:2 pull-down” (Fig. 2).



## video-processing ICs

In this process, the first film frame is shown for three fields, the second for two fields, and so on. This maps two frames of the film (1/12 sec) into five fields of the video (also 1/12 sec), thereby precisely converting the 24 frames/sec into 60 fields/sec. Out of every 10 fields (four film frames), there will always be two identical even fields that came from a single film frame, followed later by two identical odd fields that came from another film frame. These fields are shown shaded in Fig. 2.

These identical fields are quite easy to detect, using a motion detector, so the 3:2 cadence can readily be found. This, in turn, tells which pairs of odd and even fields came from the same film frame and which, by definition, have no intra-field motion, allowing them to be merged during de-interlacing, regardless of the motion in the sequence. This process is usually referred to as film-mode

detection, and is also called reverse (or inverse) 3:2 pull-down detection. The technique was invented by Faroudja Laboratories about 10 years ago, and is in fairly common use today.

It is not possible to use 3:2 pull-down detection in the teleciné conversion of 24-frames/sec film to 50-fields/sec PAL. Instead, the film is made to run at 25 frames/sec, so that one film frame exactly matches one pair of video fields, a process known as "2:2 pull-down." Because this does not result in any identical fields (only one odd and one even field ever comes from one film frame), it is not possible to use the same technique in de-interlacing as that used for 3:2 pull-down. Instead, a field-based method is used to determine which field pairs are most likely to have originated from the same film frame.

De-interlacers that incorporate film-mode detection always start by looking for the 3:2

or 2:2 pull-down sequences. If one of these sequences is detected, the de-interlacer uses it to synchronize the odd and even field pairs that are to be merged because this always produces the best possible image.

Prioritizing film mode over video is called content-adaptive de-interlacing. Great care must be taken in the editing process because, if NTSC video is edited after the teleciné conversion, the 3:2 cadence is very easily broken, resulting in a "bad edit." In fact, only if cuts are made in multiples of 10 fields will the cadence not be broken.

Bad edits, in principle, should never occur in the editing of PAL material because only pairs of fields should ever be edited out of the sequence, leaving the 2:2 cadence correct. But in practice, this rule can be broken. If this happens, the film-mode detector will instantly go out of sync and incorrect field pairs will be merged, resulting in terrible motion artifacts. This can be eliminated by a circuit known as a "bad-edit detector," which looks for feathering, the telltale effect of incorrect field pairing. This is best done one field ahead of what is being outputted to the display. As soon as feathering is detected, the bad-edit detector instantly forces the system out of film mode and triggers the film-mode detector to begin searching for the new 3:2 or 2:2 cadence, so that the system can go back into film mode as quickly as possible. Not all de-interlacers incorporating film mode have this feature, and the lack of it makes bad edits highly visible on the display. ■

## LOOKING for Anti-Reflective Film?

### ESI OFFERS:

- **AR FILM** - Multi-Layer Anti-Reflective Coating on PET or TAC
- **AR/AG FILM** - Multi-Layer Anti-Reflective Coating with "Non-Glare" Matte Surface on PET

\* All films available with or without pressure sensitive adhesive.

### ESI ALSO OFFERS:

- ANTI-REFLECTIVE GLASS AND ACRYLIC
- OPTICALLY BOND SUBSTRATES
- PRIVACY FILTERS
- EMI/RFI SHIELDING
- IR BLOCKING FILM
- HIGH VOLUME LAMINATION CAPABILITIES
- SUBCONTRACT MANUFACTURING

Custom filters and display enhancing optical films to meet all of your needs.

348 CIRCUIT STREET • HANOVER, MA 02339  
PHONE: **781-829-0808**  
www.eyesaverinternational.com



Please send new product releases or news items to Information Display, c/o Palisades Convention Management, 411 Lafayette Street, 2nd Floor, New York, NY 10003.

# SID '03

Symposium, Seminar,  
and Exhibition

Baltimore, Maryland

Baltimore Convention Center

May 18-23, 2003



# Combining High Definition with NTSC: Part II

*The approaches described in Part I provide solutions to many video-conversion problems, but HD requires the addition of more-advanced techniques for high-quality imagery.*

by Gwyn Edwards

**W**Henever a film-mode detector does not detect the 3:2 or 2:2 pull-down cadence in a signal, it means that the source was an interlaced video camera. In this case, the de-interlacer must revert to using motion-adaptive processing. A serious problem is that when spatial interpolation is being used on moving images, diagonal edges – actually all edges that are not either horizontal or vertical – become very jagged because the missing pixels are interpolated from those above and below, which do not correspond to the edge itself.

This problem was solved by Faroudja Laboratories when it developed an up-converter for the HD-broadcast market in 1996. Broadcasters of the time complained that the jagged edges in the upconverted signal were not acceptable for a “high definition” signal even though the signal was not really high definition at all; it was only upconverted NTSC! But the market was speaking loud and clear, and Faroudja responded by inventing the Directional Correlational De-interlacing (DCDi™) algorithm that dynamically detects the directions (or angles) of edges in the image. A vector-interpolation algorithm, correlated to these angles, is then used in place of the standard vertical interpolation (Fig. 1). This is called Edge Adaptive De-interlacing, a technology that was instru-

mental in earning Faroudja its third Emmy award in 1999. The algorithm is now incorporated into the Genesis Microchip de-interlacers that have been derived from earlier Faroudja products, and will be standard in all future Genesis Microchip de-interlacers. Products that use these chips frequently display the “DCDi by Faroudja” logo on their front panels.

### De-interlacing Using Motion Compensation

Another technology that has been heavily researched is the use of motion compensation in de-interlacing. This is a technique that tracks the motion of “objects” in the image from frame to frame and uses an inter-field temporal interpolation algorithm to predict the missing lines in a field for de-interlacing purposes. By using inter-field temporal interpolation instead of intra-field spatial interpolation, the loss of vertical resolution can be

eliminated. But this is not an easy process to implement in practice because categorizing real images into a number of “objects” is difficult at best – and impossible at worst. When the process works, the results are superior to motion-adaptive de-interlacing, but if the process is subject to breaking down with any regularity the results can be abysmal.

### Leveraging Motion Detection

Since a motion-adaptive de-interlacer requires both a motion detector and frame memory, it makes complete sense to capitalize on these assets and use them to add other functionality at very low cost. Two such functions are cross-color suppression and 3-D noise reduction.

Cross-color is an artifact caused by the imperfect decoding of composite video that results when high-frequency luma components are incorrectly decoded as chroma signals. This produces colorization where there



Fig. 1: Motion-video de-interlacing is shown with and without DCDi™.

*Gwyn Edwards has worked in the field of video processing since joining Faroudja Laboratories, now a division of Genesis Microchip, Inc., 2150 Gold Street, Alviso, CA 95002; telephone 408/934-4538, fax 408/262-6365, e-mail: gwyne@genesis-microchip.com.*

Genesis Microchip, Inc.



should be none and can be seen in many types of "busy" scenes, including tiled rooftops, herringbone-patterned clothing, and leafy scenery.

Probably the most annoying feature of the cross-color artifact is that it flickers at a 15-Hz rate, which makes it very attention-getting. It can be eliminated in still images by using temporal averaging of the chroma signals, the same technique that is used in a 3-D comb filter. But this cannot be done wherever there is motion because of the motion artifacts it would produce, just as in the field-weaving method of de-interlacing. The solution is to use the motion detector to selectively perform the temporal filtering only where there is no motion in the image and to use the already existing frame memory for the necessary chroma storage.

There are two basic ways of reducing noise in TV signals. Low-pass filtering reduces the noise level at the expense of the sharpness of the image, and temporal filtering reduces the noise to a very low level at the expense of motion artifacts. The optimum solution is to use a temporal filter in conjunction with the motion detector to control the level of noise reduction according to the amount of motion. Again, the already existing frame memory is used for the storage required.

### Scaling

Horizontal and vertical scaling can be used simply for changing the resolution of an image, *i.e.*, to upconvert an image from standard definition (SD) to high definition (HD), to change a wide-screen image to full-screen on either a 4:3 or a 16:9 display, or to match an image to the characteristics of a pixelated display. The scaling can also be used to change the aspect ratio of an image, *i.e.*, to show a 4:3 image on a 16:9 display in its correct aspect ratio by adding bars on the left and right to fill the screen, while the image itself occupies a 4:3 area in the center.

Another application of scaling is to show a 4:3 image on a 16:9 screen in a non-linear fashion, so that the image maintains its correct aspect ratio in the central region of the screen, but, as the image approaches the sides, it is progressively upscaled so that the original image fills the screen. Such non-linear scaling is a popular way to show 4:3 images on wide-screen TVs because it preserves the aspect ratio in the center, where most of the action occurs, without adding the annoying

side-bars. This is an important concern in phosphor-based displays such as CRTs and PDPs, in which a constant picture in any place can "burn in" the phosphors. Since most TV content today is not wide-screen, this is definitely a serious issue.

### Frame-Rate Conversion without Tears

If the image timing on a display changes at any point except during the vertical blanking interval (VBI), the image will momentarily tear at the change point. In many information-display applications, it is not important that changes be done in a way that is tearless because the image does not change frequently and, even when it does, only small portions of the image change at any one time, significantly reducing the probability that the tear will be visible. But video images are typically undergoing full-screen changes constantly,

and in this case it is very important that the changes occur only during the VBI to avoid tearing.

In their FLI2300 de-interlacer, Genesis Microchip uses double buffering and synchronization circuitry to ensure that the frame-buffer readout is always done in such a way as to avoid tearing when the readout rate is different from the write rate. Frame-rate conversion is required in all applications where different mutually asynchronous sources must be displayed simultaneously. TV with picture-in-a-picture (PIP) is an example.

### Non-Linear Video Enhancement

Because the bandwidth of all TV systems – especially SD TV systems – is limited, the sharpness of the images shown on these systems is nowhere near that which most displays are capable of showing. This is particularly

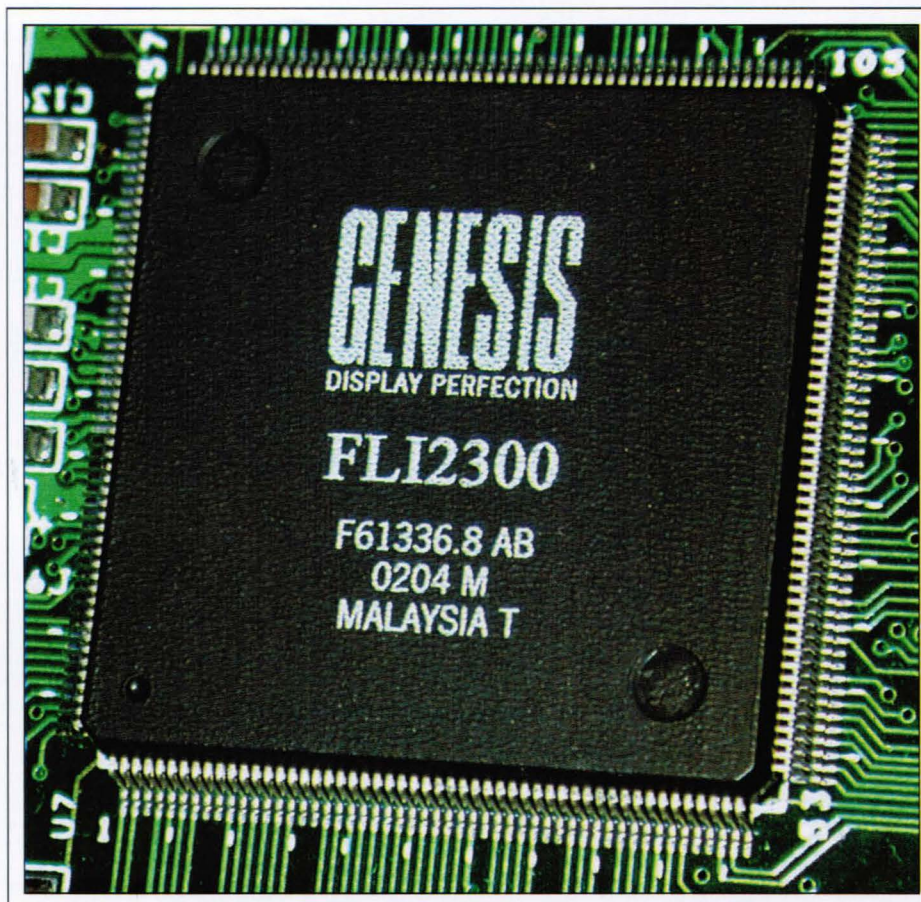

Genesis Microchip, Inc.

**Fig. 2:** The FLI2300 chip integrates many video-processing functions, including motion-adaptive de-interlacing with film mode, DCDi™, cross-color suppression, noise reduction, scaling, video enhancement, and frame-rate conversion.



## video-processing ICs

true when the images are upconverted for high-resolution displays.

The classical way of sharpening an image is to use a high-pass filter to enhance the signal levels in the vicinity where the bandwidth limitation makes the levels roll off. This is fine if the signal is very clean, but any noise will also be enhanced! In addition, the excessive use of high-frequency boosting in this way can introduce ringing into large signal transitions such as sharp edges in the image.

Faroudja Laboratories worked on non-linear digital techniques for many years to come up with a series of algorithms for video-signal enhancement that does not introduce any of these artifacts, culminating in the TrueLife™ enhancement technology that also contributed to the company's winning its 1999 Emmy award. Unlike conventional high-frequency peaking, the algorithms are time-domain based and operate on both horizontal and vertical transitions in the signal. This represents a further advance over conventional sharpening, which can normally be done only horizontally.

Two thresholds are specified for transition amplitudes. The first threshold defines transition levels below which transitions are considered to be noise, so no enhancement is applied to these transitions for obvious reasons. Between the two thresholds, the transitions are considered to be "detail," which includes textures, fine features such as hair, etc. These are deliberately exaggerated to make them stand out more prominently and make the image seem more lifelike. Above the second threshold, the transitions are considered to be "large edges," or transitions between one object and another (or a background). If the detail-enhancement algorithm were to be applied here, the result would be very bad ringing. Instead, these transitions are sharpened to make the edges in the image sharper, which enhances the perception of 3-D by making foreground objects stand out more against the background. This algorithm actually extends the bandwidth of the signal significantly and is sometimes referred to as "bandwidth expansion." Although these techniques can be employed with any video signal, they perform exceptionally well on signals that have been upconverted. This is so because without any enhancement such signals will contain no more detail or sharpness than the signals from which they were derived.

### Putting It in Silicon

Until very recently, all of the technologies that have been discussed were available only in separate devices. Within Genesis's line-up, the FLI2200 de-interlacer included motion-adaptive de-interlacing with film mode, DCDi™, and cross-color suppression. Noise reducers were typically separate devices; and so were scalers and frame-rate converters; and the video enhancer – the FLI2220 in Genesis's case – was also a separate device.

Now, thanks to continuous improvements in semiconductor technology, we have been able to combine all of these functions in a single device, the FLI2300 family (Fig. 2). The family actually consists of three devices: the FLI2300, which has both analog and digital outputs; the FLI2301, which adds the Macrovision and CGMS-A copy-protection systems to the analog outputs for DVD-player applications; and the FLI2310, which has digital outputs only. As time goes on, even higher levels of integration will be possible, and this will result in greater cost savings for manufacturers of consumer products.

### Buy HD TV Now?

Although further integration will reduce costs, current technology gives a high-quality image on common HDTVs up to about 60 in. In fact, further improvements in perceivable image quality will be evolutionary from now on – unless some spectacular new technology appears.

So, is this a good time to invest in HDTV products? It depends. If one is planning to buy a new TV soon, I would suggest buying an HD-ready set – if not a true HDTV – because it is going to be operable into the period when all TV programming will be ED or HD, and one would probably not want to watch those programs downconverted to SD quality. On the other hand, if one bought a new TV in the last two or three years, it might be premature to think of getting rid of it just yet, unless another use for it can be found.

Somewhere between these extremes are many consumers who have an older, but still perfectly serviceable, TV set and are wondering when the time will be right to buy HDTV. I would say very soon, but since the majority of programming is still SD, it is important to buy a product that performs high-quality upconversion of these images. (Most do not, and this is a common complaint among video-product reviewers.) But even when the pro-

gramming is SD, a good HDTV with a high-quality de-interlacer and scaler can make these images look almost as good as real HD, and that is the key. These products are now becoming available in the marketplace, but check the product reviews in home-theater magazines before buying. ■

18 <sup>03</sup>

FEBRUARY

3rd International Display  
Manufacturing Conference  
& Exhibition (IDMC '03)

TAIPEI, TAIWAN  
FEBRUARY 18-21, 2003

- An international gathering of display scientists, engineers, manufacturers, marketers, integrators, users, analysts, consultants, and investors, where all aspects of display manufacturing will be discussed.
- Sponsored by the Korea Chapter of the Society for Information Display.

15 <sup>03</sup>

SEPTEMBER

The 23rd International  
Display Research Conference (IDRC 2003)

PHOENIX, ARIZONA  
SEPTEMBER 15-18, 2003

- An international conference on display research and development aspects of:
- Display Materials (liquid crystals, small-molecule and polymer OLEDs, phosphors, optical compensation films, flexible substrates, etc.)
- Display modeling, Design and Processing
- Display Systems and Human Interfaces



# Hard Solutions to Soft Problems

*A highly integrated chip provides GUI support for embedded systems with LCDs.*

by Jerry Shapiro

**T**WO of the most important factors in the success or failure of a new product are development costs and time to market. This is especially true for designers of embedded systems because their markets are price sensitive and the demand for rapid delivery schedules is intense. Now, a small company has developed a single piece of silicon that can have a major impact on both factors.

A user's first impression of an embedded product is often based on his or her first experience using the graphical user interface (GUI), and the user's judgment of the overall product is likely to be based largely on this interface (Fig. 1). But designing a high-quality GUI takes time and programming resources, both of which can be expensive. The Easy GUI™ controller chip from Amulet Technologies is an example of how software-development tasks and processing can be moved to a co-processing chip that also provides LCD-controller functions, thereby lowering development costs and speeding new products to market.

## The Programmer's Burden

In recent years, users have demanded increasingly complex user interfaces in response to growing lists of product features. This demand has put greater pressure on programmers. The amount of code written to run a GUI often consumes as much as half of a

*Jerry Shapiro is Marketing Communications Director at Amulet Technologies, 275 Saratoga Ave., Suite 230, Santa Clara, CA 95050; telephone 408/244-0363 x105, fax 408/243-5457, e-mail: sales@amulet-technologies.com; URL: www.amuletGUI.com.*

product's code requirements. More code for the GUI means additional costly development and testing time. To handle the larger amount of code, designers are forced to incorporate a larger, more expensive microprocessor.

A significant majority of embedded-systems products still rely on 8-bit microprocessors. Ironically, current GUI solutions are influenced by the windowed operating systems of the personal-computer world, and are thus targeted toward 32-bit processors that have the horsepower and memory required to execute graphics software. Unfortunately, these solutions further increase the amount of software that must be written and executed.

Many solution providers have tried to simplify the software-development process by providing collections of code that can be adapted and customized. One approach has been to provide graphics libraries to product developers.

## Graphics Libraries

Typically, graphics libraries provide tools for implementing text and graphics. The use of these libraries often requires payment of licensing fees or costly upgrades to implement their full functionality. The two basic levels of graphics libraries are drawing libraries and object-oriented GUI libraries.

At the lowest level, drawing libraries provide the ability to create lines, boxes, arcs, bitmaps, and text. But there are many additional attributes required to draw something as simple as a box. Is the box filled? What is the line thickness? Are the corners rounded? Each of these attributes can require many lines of code, which in turn requires programming time.

Drawing libraries provide only limited help because a GUI requires much more than mere geometric shapes. Displayed objects must also accommodate behaviors linked to user or program events. For example, a displayed button may look different when pressed. These differences require that the product developers provide additional programming code. As a result, the embedded microprocessor must use computing cycles to draw the objects and implement the GUI behaviors while continuing to execute the main product application. This requires very complex code that must determine the appropriate circumstances and timing to alternate between these tasks. Once completed, even small changes to the GUI can require major rewrites of the code, which slows development and increases costs.

Object-oriented GUI libraries provide more help than simple drawing libraries by making it possible to display the same object with different properties without having to write code for each instance. For example, four displayed check boxes can have different labels



*Fig. 1: A well-designed GUI helps to create a positive user experience.*



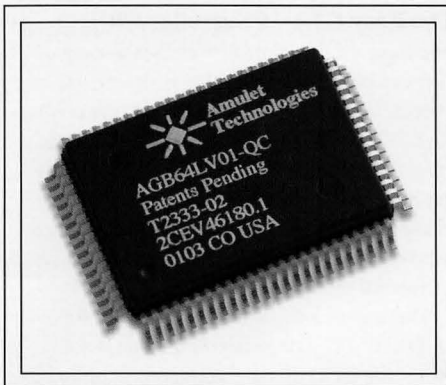

Amulet Technologies

**Fig. 2:** The Amulet Easy GUI™ controller chip provides user-interface support that would otherwise have to be handled by software running on a product's embedded processor.

and functions without having to code unique routines for each check box.

However, object-oriented GUI libraries require more processing power. In fact, the majority of these libraries are designed to run on the much costlier 32-bit microprocessors, which can limit hardware choices and require a costly hardware upgrade. Typically, these libraries only run on dedicated operating systems that are purchased separately. This not only adds cost but usually requires specialized training for the developers.

Even when using a graphics library, additional support in the form of utilities is needed. Authoring tools are needed for screen layout and navigation, as well as bitmap and font-conversion utilities. Usually these tools must be created by the programmer and are specific to the product hardware. Some high-end object-oriented libraries may offer these utilities, but they are usually costly add-ons.

### Hardware Trumps Software

Amulet Technologies uses cost-effective silicon to supplant costly software development. The Amulet controller chip (Fig. 2) replaces the traditional LCD controller and the software required to drive it. It is a combination of an LCD-controller chip and a GUI operating system. This technology eliminates the need to write complex software to draw each pixel on the LCD.

By taking over the GUI management, the chip frees the embedded microprocessor to do its job more efficiently. Thus, the main application can run on a smaller processor with less

RAM and ROM, and code development and maintenance time is significantly reduced.

Amulet's chip is a graphical client driven by an HTML markup language that is similar to that used by Web browsers. The markup language features the hypertext ability to provide links to different types of information from many remote sources. Unlike the large software-based Web browser, however, the Amulet GUI browser is a small application-specific integrated circuit (ASIC) designed to remove the burden of GUI execution from the resource-starved 8-bit processors used in the bulk of embedded-systems applications.

Standard HTML authoring tools, such as those sold by Adobe, Macromedia, and Microsoft, can be used to create and arrange user-interface elements. Elements that require a response to user or processor events are linked to event "callback" routines through HTML hypertext links. The Amulet compiler supports JPEG and GIF images, including animated GIFs. A font converter is also included for converting any Windows font to an Amulet font.

Although the HTML can be viewed on a conventional Web browser during prototyping, the chip is neither a PC-based Web browser nor an Internet device; therefore, the HTML code must be converted. Prior to being viewed on the Amulet UI hardware, the HTML is compiled to Amulet's proprietary format called  $\mu$ HTML™ to reduce its size and execution requirements.

The  $\mu$ HTML is stored in flash memory and served to the Amulet UI hardware. Once served, the UI browser hardware renders the interface to the LCD, interacts with the user-input hardware, and updates the display to provide visual cues to acknowledge the user and processor events – all without burdening the main processor.

### Amulet Widgets

To further speed development, the HTML features are enhanced through a custom library of user-interface components called Amulet Widgets (Fig. 3). These are user-input objects common to embedded systems, but not supported by standard HTML. Widgets provide user-input functions such as function buttons, radio buttons, and check boxes, as well as display-data functions such as bar graphs, line plots, numeric fields, and text strings.

Generally, widgets are tied to an external variable, graphics files, or other  $\mu$ HTML pages. Widgets are designed to functionally interface with the embedded microprocessor (or other embedded device) via the Amulet serial protocol.

To simplify the task of incorporating these widgets into user-input pages, an HTML template of widgets is included with the development software. This enables the programmer to cut and paste widgets into GUI pages as needed.

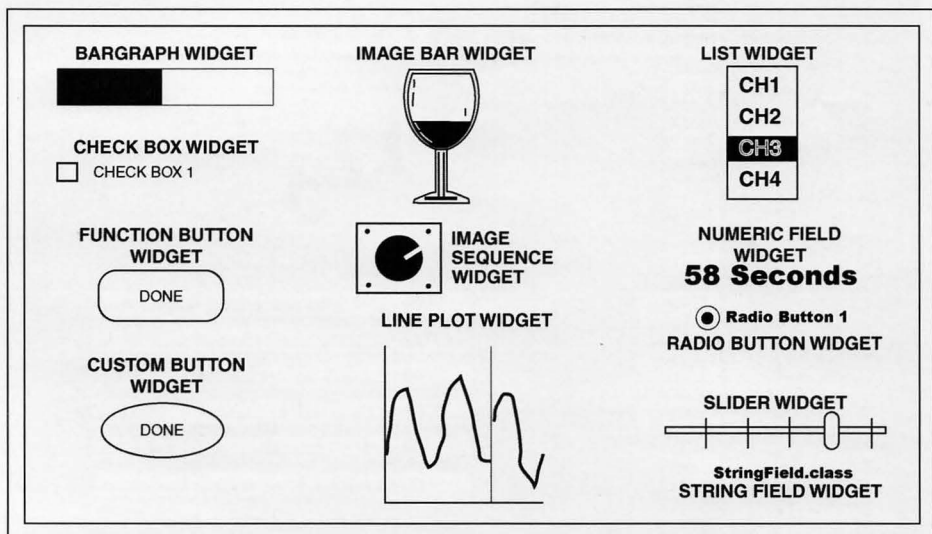

**Fig. 3:** Amulet's GUI library of Amulet Widgets includes user-interface objects not supported by standard HTML.



## case study

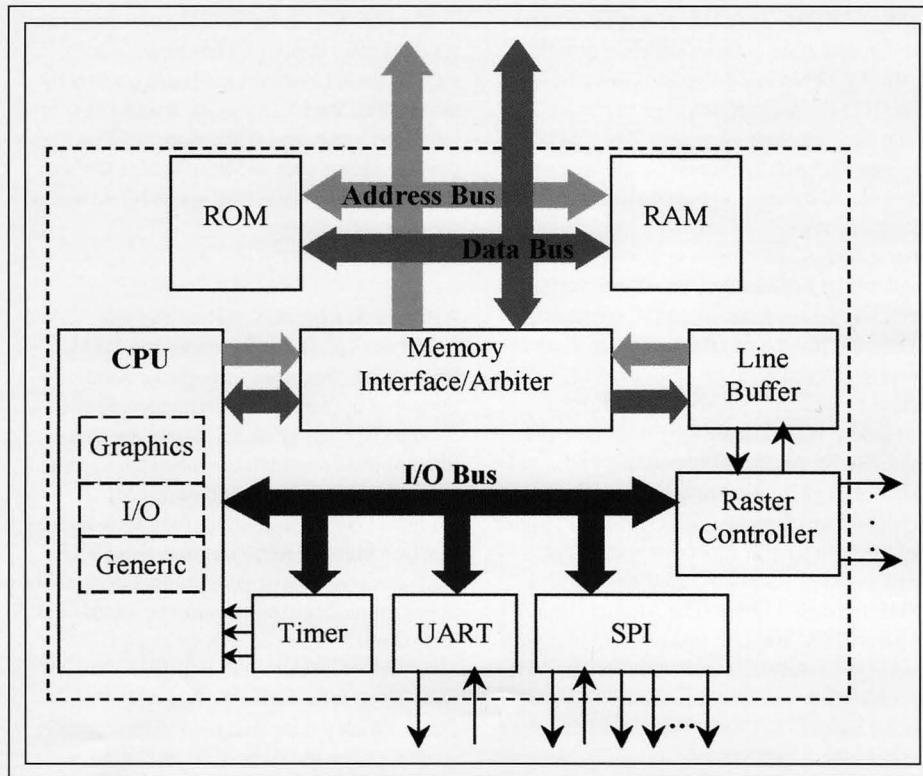
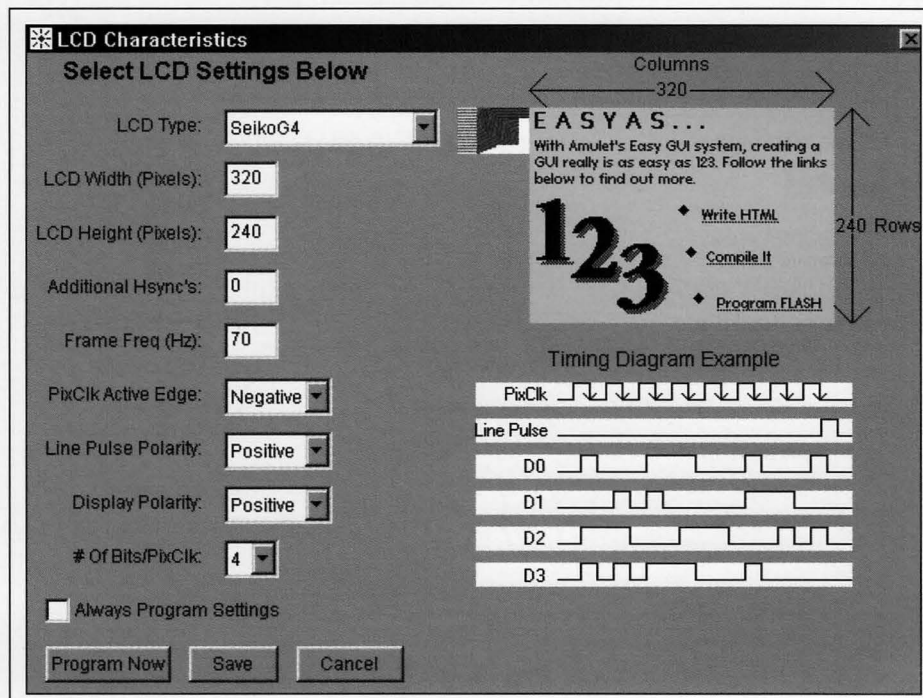

Fig. 4: The Easy GUI™ controller chip is highly integrated, containing the circuitry required to provide the functions of many peripheral devices.



### The Easy GUI™ Controller Chip

The Easy GUI™ controller chip is a special-purpose microcontroller that is optimized to execute Amulet's GUI kernel and component-based GUI firmware. It is an 80-pin plastic quad flat pack (PQFP) ASIC with the following built-in components: LCD controller, microprocessor, universal asynchronous receiver-transmitter (UART), timer, and serial peripheral interface (SPI) master (Fig. 4).

There are 13 dedicated output lines for LCD control. The bias voltage that determines the LCD driving voltage is supplied by an external source so that the chip is able to drive displays of different sizes.

Settings within the Amulet compiler are used to specify display manufacturer or size, as well as frame frequency and clock polarity (Fig. 5). The chip supports most monochrome single-scan displays up to full VGA. Because of its high level of integration, the chip requires relatively few peripherals (Fig. 6): 3.3-V power supply, serial flash memory (Atmel, 1-Mbit minimum), asynchronous static RAM (64k × 8 minimum, 30 nsec @ 16 MHz), and a clock or crystal (up to 20 MHz).

Although there is only a single Von Neumann CPU, the CPU features task-specific opcodes, registers, and memory segments for three very different types of tasks: graphics rendering, I/O processing, and general-purpose computing. This architecture enables the GUI kernel firmware to implement an efficient task scheduler, and graphics and I/O tasks are implemented with a minimum of CPU cycles and code space.

The line buffer is a parallel-loaded shift register with a maximum capacity of 256 bytes. It is responsible for periodically burst-fetching a block of pixel data for each raster line from the frame buffer. To minimize the burst period, the line buffer was implemented as a dual-ported synchronous SRAM block capable of reading a single byte in a single CPU clock cycle.

To minimize external pin and component count, only a single external memory bus is implemented. Because both the CPU and line buffer require access to external memory, a memory-interface unit is employed to resolve arbitration issues and to direct the flow of data

Fig. 5: Compiler settings make it easy for developers to support most monochrome single-scan displays up to full VGA.



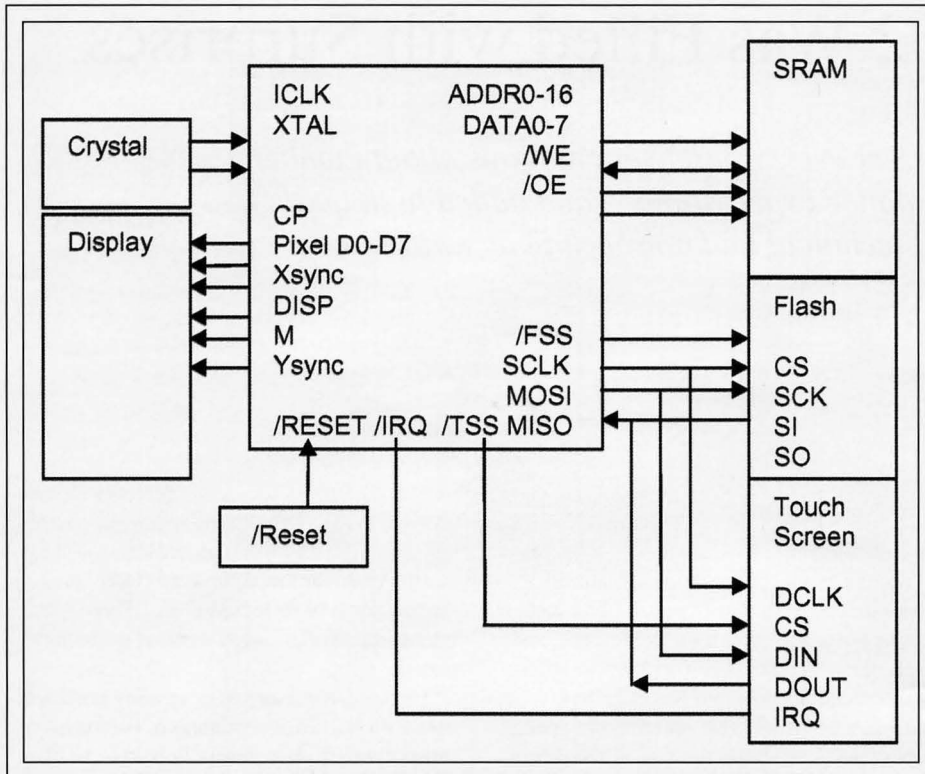

**Fig. 6:** This typical system block diagram for the Easy GUI™ chip demonstrates why it requires relatively few support peripherals.

and address signals. The CPU also features a separate I/O bus linking the following on-chip peripherals to the CPU's I/O task: an LCD raster controller, three timers, a UART, and an SPI master with eight slave selects.

The LCD raster controller is a unique peripheral. It is responsible for converting the line-buffer data to signals conforming to standard LCD interfaces. These include horizontal and vertical syncs, as well as a serially

shifted data stream of pixel data and a shift clock.

In addition to the chip-level solution, Amulet Technologies also offers LCD-controller boards and modules with the chip on board (Fig. 7). Several LCD companies, such as Hantronix, Emerging Display Technologies, Light Array, and PixTech, are using Amulet's technology to demonstrate displays. Hantronix also offers LCD-evaluation kits that incorporate the Amulet chip.

### Time and Money

By reducing the amount of time required to develop GUI systems for embedded-device products with LCDs, the Easy GUI™ chip reduces development costs and shortens development cycles, which can provide important competitive advantages in the marketplace. This hardware solution delivers bonus benefits by taking over much of the display-processing load from the CPU, enabling the entire product to run more efficiently. ■

Please send new product releases or news items to Information Display, c/o Palisades Convention Management, 411 Lafayette Street, 2nd Floor, New York, NY 10003.



Amulet Technologies

**Fig. 7:** Amulet's 5.7-in. LCD starter kit makes it easy for product developers to create custom GUI systems.

18

03

FEBRUARY

3rd International Display  
Manufacturing Conference  
& Exhibition (IDMC '03)

TAIPEI, TAIWAN  
FEBRUARY 18-21, 2003

- An international gathering of display scientists, engineers, manufacturers, marketers, integrators, users, analysts, consultants, and investors, where all aspects of display manufacturing will be discussed.
- Sponsored by the Korea Chapter of the Society for Information Display.



## EuroDisplay 2002 Was Filled with Surprises

*In a year when conference organizers everywhere were nervous about numbers, EuroDisplay 2002 exceeded attendance expectations – and added high quality, a much-appreciated location, and technical and non-technical surprises.*

by Ken Werner

**A**S EURODISPLAY 2002, held in Nice, France, October 1–4, wound down at Nice's Acropolis Congress Center, Alain Doré, Chair of the EuroDisplay Steering Committee and President of Club Visu SID-France was an obviously happy man. Doré, who had clearly been relieved early in the week at having received 500 pre-registrations, was delighted when the all-but-final numbers turned out to be 627 registrants for the conference and 230 for the Tuesday seminars. These are high numbers for EuroDisplay, which is the name for the International Display Research Conference (IDRC) when it is held in Europe every third year. (The conference is called simply IDRC when held in North America, and Asia Display when held in Asia.)

The regional breakdown of attendees was 353 from Europe, 215 from Asia, and 58 from North America. Within Europe, the leading five countries were France (136), Germany (48), The Netherlands (47), the U.K. (31), and Belgium (20). Within Asia, the top four countries/regions were Japan (118), Korea (70), Taiwan (16), and mainland China (4). Within North America, the order was U.S. (52) and Canada (6). It is likely that the appeal of Nice and the surrounding area contributed to the conference's good attendance. Several registrants told *Information Display* that they had come early or were staying after the conference to enjoy the area.

**Ken Werner** is Editor of *Information Display*; telephone 203/853-7069, fax 203/855-9769, e-mail: [kwerner@sid.org](mailto:kwerner@sid.org).

But the technical program – organized under the leadership of Program Chair Robert Meyer – was the core of the conference, and everyone who discussed it with *Information Display* said the program was excellent. European activities were presented in greater depth than is generally the case at non-European international meetings, and Asian and

North American speakers were clearly presenting some of their best work. There were interesting revelations in some of the technical papers.

The conference began generating good feelings with its day of seminars on Tuesday, most of which were generally held to be of superior quality in both content and presenta-



Ken Werner

*Nice's Ville Vieille – the old city – was a modest walk from the Acropolis Congress Center and a popular place for EuroDisplay attendees to walk and eat.*





Ken Werner

Nice's Acropolis Congress Center was EuroDisplay's home for the first four days in October 2002.

tion. Doré credited Seminar Chair Jean-Pierre Budin and Jean-Pierre Bouron with assembling the seminar program.

Among the 12 seminars were a clear technological description and comparison of bistable-LCD technologies by Alain Boissier (Nemoptic, Magny les Hameaux, France), a remarkably comprehensive survey of organic and polymeric LED technology by Kathleen M. Vaeth (Eastman Kodak, Rochester, NY, U.S.A.), an investigation of the roads toward improved performance and reduced cost in manufacturing PDPs by Harm Tolner (Philips Components, Eindhoven, The Netherlands), and a tutorial on modern video processing for digital and flat-panel displays by Sébastien Weitbruch (Thomson Multimedia, Villingen, Germany).

### Keynotes

The surprises started with the Wednesday Keynote Session when a more-than-normally contentious question greeted each speaker. Bruce Berkoff (Executive V.P. of Marketing, LG.Philips LCD) led off with "The Display-centric Home and Office of Tomorrow," in which he outlined a future in which displays

are used for many applications and the number of displays per capita increases dramatically. Early in his presentation, he showed a video illustrating potential applications in a "display-rich and, hopefully, user-friendly

future," in which there will be "less technology to deal with; more technology to use." LCD TV, said Berkoff, will be an important part of that expansion, with 15-20% of the TV market being in LCD by the end of the decade. "And TV is where the glass area is. We do not see 20-in. laptops or 30-in. desktop monitors, but there *will* be 30-in. LCD TV sets." Berkoff does foresee monitors that use two or more LCDs becoming more common.

In another section of the talk, Berkoff commented that at some point, further increases in the size of LCD motherglass will not be functional. There will be Gen 6 fabs, he said, but there might not be Gen 7 fabs. (Berkoff commented that although Sharp is describing the new fab it is constructing as a Gen 7, it is really a Gen 6 by the standard definition that Gen 6 uses motherglass between 1500 and 2000 mm along its largest side.)

When it comes to large-screen TV, Berkoff sees PDPs getting squeezed between large LCDs and microdisplay projectors because of the cost liability associated with PDP's high-voltage drivers.

During the question period, the distinguished and usually genial Heiju Uchiike, formerly a senior designer for Fujitsu and now a professor at Saga University, stated forcefully that the power consumption of 42-in. PDPs was now close to that of similarly sized LCDs. Berkoff acknowledged this, but observed that PDPs have a 10-year lead on large-screen LCDs. "Give us another year or

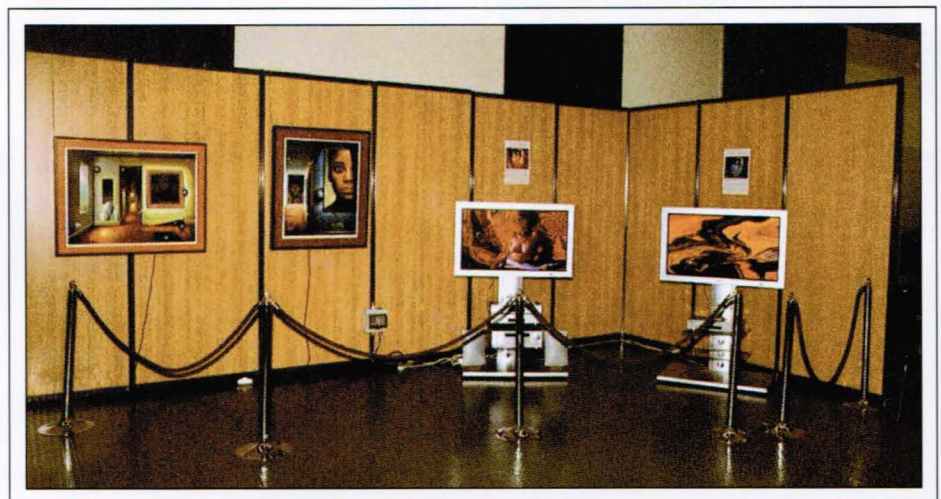

Alain Doré

The "art corner" was an unusual and popular addition to the exhibit area. On display were dynamic art works by Claude Massot, which he calls *l'Art Numérique*, and collaborative works containing LCDs by Zvi Yaniv and his associates.



## EuroDisplay Trip to Eze



Ken Werner

Street performers entertain EuroDisplay registrants in the fortified medieval village of Eze.



Ken Werner

Even with clouds covering the sun, the view from Eze is striking.

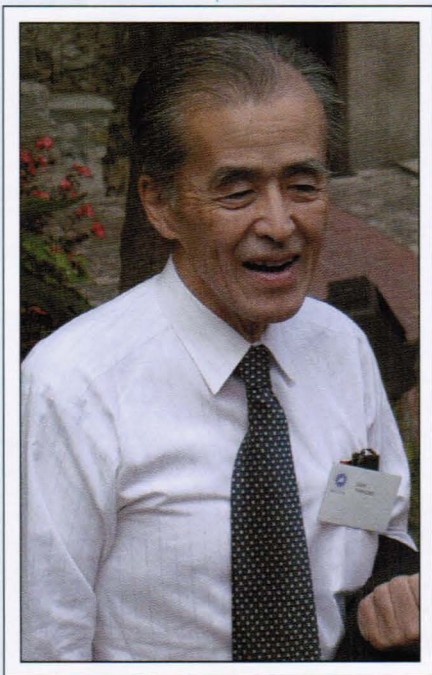

Ken Werner

Eiichi Yamazaki, now of LG Electronics, strolled through the streets of Eze.

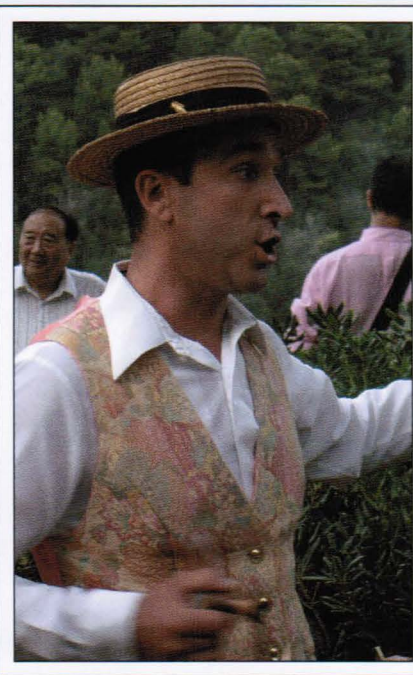

Ken Werner

Eze's street singer (foreground) and Tong Linsu (left) of the Display Technology Research Center, Southeast University, Nanjing, China. Tong is one of the organizers of ASID '03, which will be held in Nanjing, August 17-20.

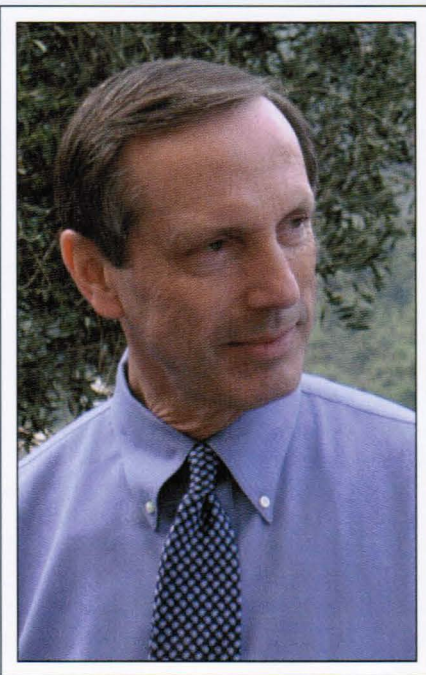

Ken Werner

SID President Allan Kmetz (Agere Systems) speaks with Tom Credelle of ClairVoyante Laboratories (out of frame) at the buffet.



two." Despite this answer, Uchiike repeated his comment more than once. From the podium, SID President Allan Kmetz (Agere Systems) said gently, "I suggest boxing gloves at the author interviews," which put an end to the confrontation.

It is possible that language differences made it difficult for Uchiike to express the full range of his opinions. In previous conversations, he has enthusiastically discussed the cost reductions that are permitting the sale of 37-in. PDP TVs for \$3500 in Japan. At ASID '02 in Singapore in early September, Uchiike told *Information Display* that he believed that further cost reductions now under development would bring the selling price of such sets down to the vicinity of \$1500 within a few years.

### The European View

In the second keynote, "Display Technology Challenges for a Human-Centered Information Society," Marc Boukerche of the European Commission (EC), filling in for George Metakides, said, "Despite today's difficult conditions in the technology market, fundamentals are in place for renewed growth." He drew parallels between the boom-bust-renewed-growth cycle experienced by railroads in the 19th century and today's Internet situation. "History shows," he said, "that those who wait for the plateau [in technology growth] find only a monopolized or commoditized market."

The next plateau, Boukerche said, is that of "ambient intelligence." After discussing its meaning and significance, Boukerche identified the technologies needed to support ambient intelligence and expressed the view that it was critical for European companies to be involved in the research and development of those technologies. That served as a stepping stone to describing the information-society technologies section of the EC's Sixth Framework Program (FP6), on which the EC will spend over €3.6 billion through 2006, as well as some of the projects supported in FP5. He focused on the CARBINE project, of which Nemoptic's BiNem™ technology was the prime beneficiary.

Those who give money to fund R&D projects are generally popular, but Boukerche was not to escape without one challenging question. John Raines said, "Your presentation focuses on expenditures, but it does not treat wealth creation. Is this considered in

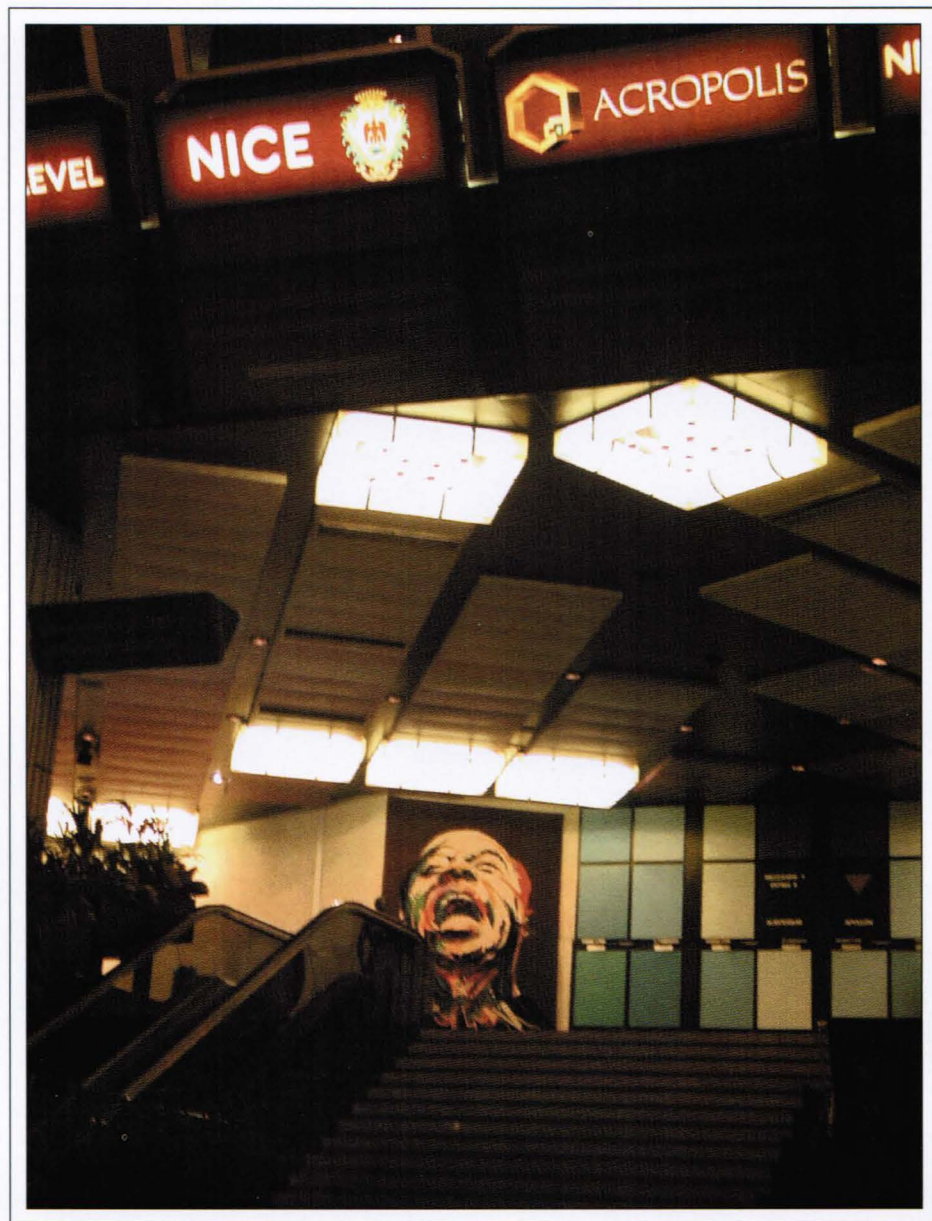

Ken Werner

*The interior of the Acropolis is striking, and generously hung with fine art.*

policy development? I ask this question in the context of much European expenditures over the years that have been exploited in Asia."

Boukerche answered that it was important for Europe to be involved in the technologies it used, and "let us not forget the income from licensing IP." Bruce Berkoff commented from the floor, saying, "That's a good question. This is a global business. We [at LG.Philips LCD] value such contributions and there are many valuable joint activities. We

are working on a project that will enable developers of IP to realize licensing income where they have not been able to do so in the past."

Things continued to be interesting as EuroDisplay rolled into the core of its technical program. Joachim Grupp (Asulab, Switzerland) discussed some of the ways the image quality and power consumption of reflective LCDs can be improved. He cited results of the European *Helicos* project that



## conference report

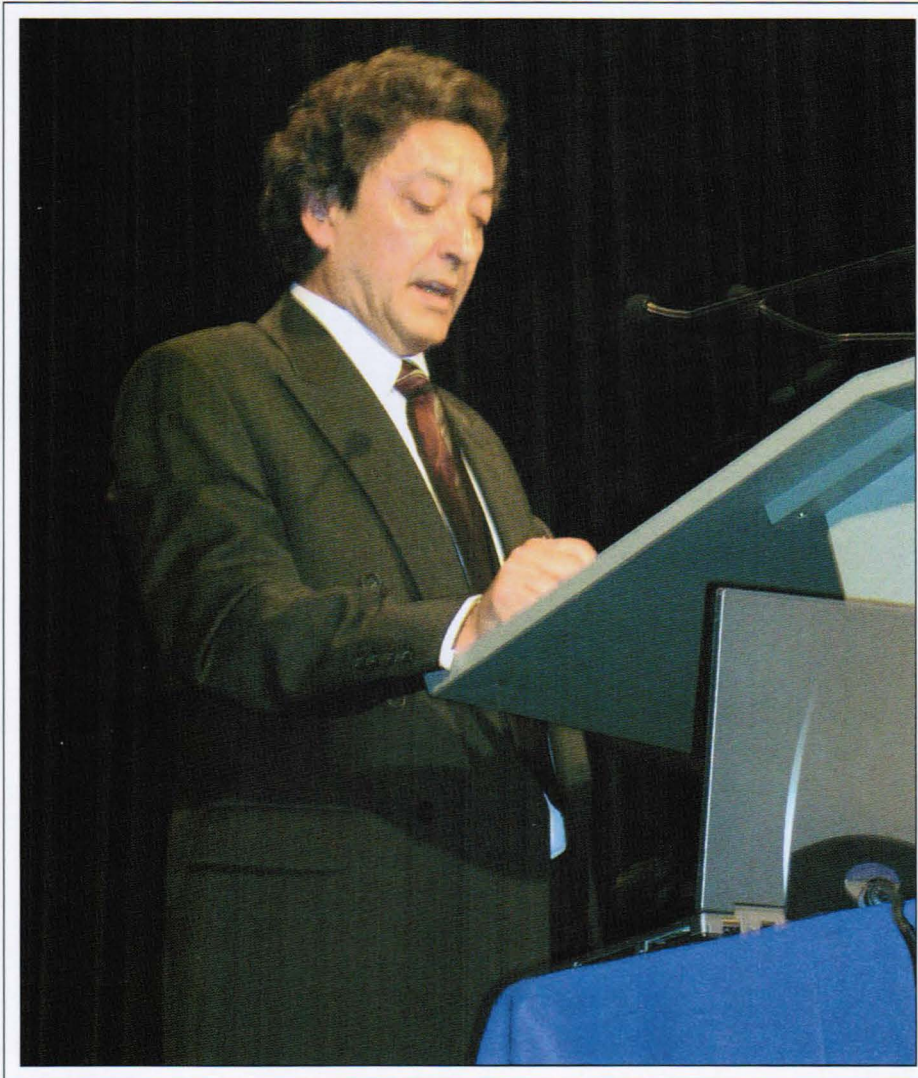

Ken Werner

Keynote speaker Marc Boukerche presented the case for EC support of European display R&D.

stacked RGB LCD cells produce a better color gamut than the best reflective STN displays with traditional side-by-side RGB subpixels.

But in reflective LCDs, more than half of the power consumption is in the display electronics, not the display, so power consumption of the electronics must be minimized. There are hardware approaches, of course, but that's not all. Grupp discussed the concept of "active power management" in some detail, which means, he said, "If you do not need a resource, turn it off." Among these resources are full frame frequency, full voltage, full gray scale, full color, and full-screen images. Use all the techniques and it is possible to get down to microwatts in special situations.

A team from Kent Displays (Kent, Ohio) described the first *transflective* cholesteric LCD (Ch-LCD), and a group from Nemoptic described a high-volume manufacturing process for the company's BiNem™ bistable nematic LCD. The authors pointed out that since BiNem displays do not use a compensation film, the structure is quite simple. The Q&A session was lively. One questioner asked about the contrast. The response was that the contrast ratio (CR) was 15:1 in the reflective mode because of reflection from the front polarizer and 200:1 in transmissive mode. Another listener asked about the anticipated market for the technology. Presenter J. Angelé said, "We expect a large market

penetration, but you will have to get the details from our marketing department."

Karl Heeks of Cambridge Display Technology (CDT) looked at the status of light-emitting-polymer materials from several manufacturers. A new blue emitter has a lifetime of greater than 5100 hours at 100 nits; a new red emitter has a lifetime of over 35,000 hours at 100 nits. CDT has been working seriously on ink-jet printing of OLED materials with partner Seiko-Epson and subsidiary Litrex. They have now gotten to the point where ink-jet devices have a power efficiency and luminance equal to that of spin-coated devices. Heeks observed that the first polymer-OLED product is now on the market – the Philips battery-life indicator that appears in some Philips rechargeable electric shavers.

A highly original approach to OLEDs was presented by Michael Redecker and his colleagues from Samsung SDI's European Research Center (Berlin, Germany) and its Corporate R&D Center (Yongin City, South Korea). OLEDs are strong display contenders for applications where the ambient illumination is low to moderate, the authors said, as are backlit LCDs. But LCD designers have been able to exploit reflective and transflective modes for high-ambient applications. An equivalent mode has not been available to OLED designers until now.

It is well known that under the right circumstances, an electroluminescent device can operate backwards, *i.e.*, instead of generating light from the radiative decay of an excited state consisting of a positive and negative charge carrier (exciton), it can absorb light to create an exciton, from which charge carriers can be extracted. (In other words, it's a photocell.)

Another characteristic of these "reverse OLEDs" is that the process just described occurs with much greater likelihood (over 80%) when a field in the vicinity of 0.3 V/nm is applied. In the absence of a field, almost all of the excitons relax by re-emitting light. What the team at Samsung realized is that this provides the mechanism for a "reflective" – actually re-emitting – OLED display, which investigators call a Field Quenching Device (FQD) because the field quenches the re-emission of the incident light. They have made a segmented-display prototype that is very readable in full sunlight, with a contrast ratio of 5:1. This was a paper that was discussed in the halls and during the coffee break.



In "Rear-Projection Technologies for Consumer Applications," Thierry Borel (Thomson Multimedia R&D) said that the main issue is the trade-off between price and quality. The necessary price for large-screen sets, he said (drawing laughter from the audience), is \$2999, *i.e.*, less than \$3000. In 2001, three million 52-in. rear-projection CRT TV sets were sold. Rear-projection LCoS is on track to beat \$3000 and eventually displace CRT rear projection, but it is unclear whether, ultimately, DLP or LCoS will dominate. He also noted that China is on track to displace the U.S. as the largest rear-projection TV market by 2004.

The EC's LCoS4LCoS program (which had a booth in the exhibit area) was established to determine the best LCoS approach. One goal is that the cost of a rear-projection engine be less than \$500.

Armand Bertinelli and Jean-Claude Martinez (Thomson Plasma, Moirans, France) presented an interesting approach to reducing the cost of plasma displays by using porous barrier ribs (PBRs) instead of the relatively dense conventional barrier ribs. The PBR is made of alumina plus a few percent of glass hardener. Not only is this material one-tenth the cost of traditional vitreous materials, the authors said, but there are also substantial downstream processing advantages. The PBR material does not shrink in the z direction when fired, and the phosphor coating can be applied onto the unfired structure. Then, the ribs are co-fired along with the phosphors and the frit seal at low temperature (480°C) in a single firing. The only concern the authors voiced about the new material is that it is not as strong as vitreous materials, but, they said, "It's strong enough."

Because the fired PBR has a high porosity of about 30%, much shorter exhaust cycles are possible – an advantage that is particularly striking with closed ("waffle-type") cell structures. The authors have made 42-in. PBR plasma panels with a combined seal-and-exhaust cycle of only 4½ hours, and stated that the performance was equal to that of conventional displays made with much longer exhaust times. The authors acknowledged support from the EC's PLADIS program.

In a lively Q&A session, Larry Weber asked if the large surface area of the porous alumina creates problems. "We have seen none," said Bertinelli. "[The alumina] may act as a getter, which is a very good situa-

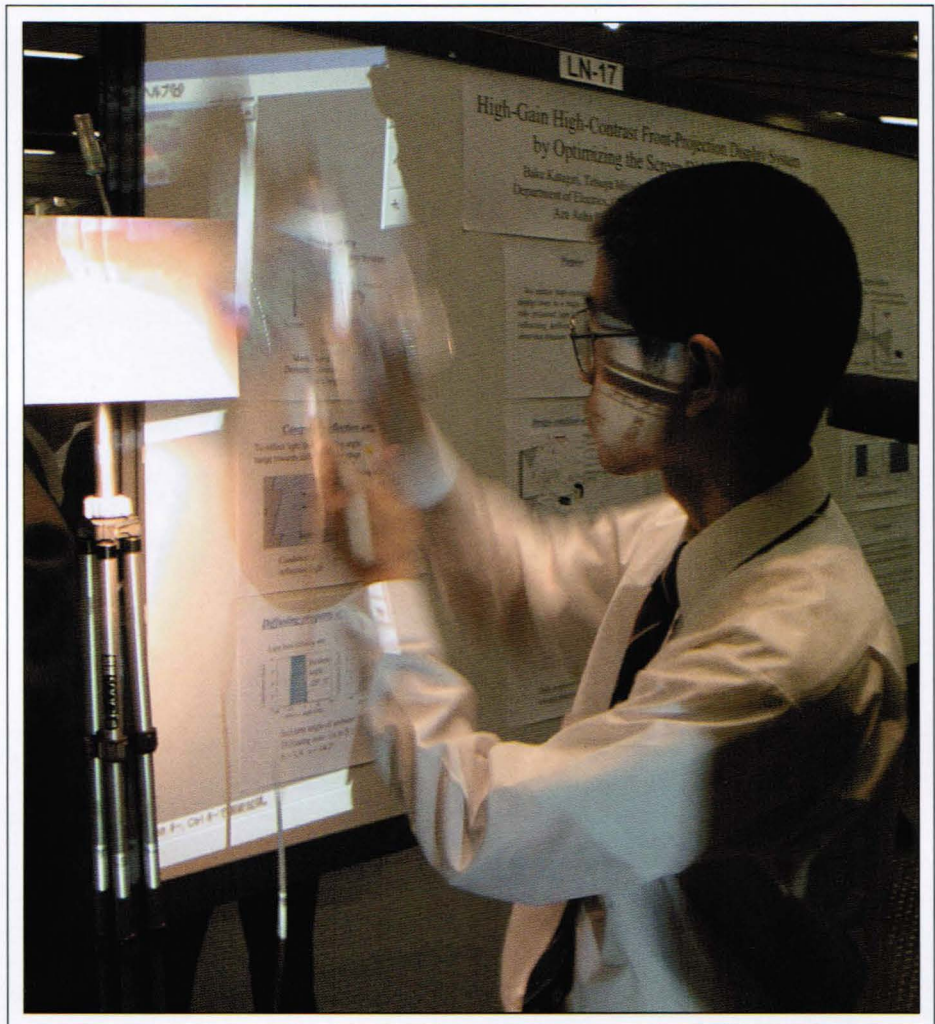

Ken Werner

*In Late-News Poster Paper LN-17, three of Tatsuo Uchida's students at Tohoku University (Sendai, Japan) described a novel front-projection screen made from a reflector and an optical film that diffuses projected light toward the viewer and reflects ambient light in other directions. The screen was impressive – and was energetically demonstrated by one of the students.*

tion." Robert Meyer added from the floor that alumina has been used for years in CRTs and other vacuum tubes, and is a very stable and well-understood material.

### Exhibits

The organizers admitted to one disappointment: the number of exhibitors was less than hoped for. But that did not mean there were not things to see. Among the familiar companies and organizations were the Deutsches Flachdisplay Forum, which is trying to establish new FPD-manufacturing facilities in Germany; ELDIM, the French maker of conoscopic measuring instruments for displays;

LC TEC Automation of Sweden; Nemoptic of France; ROLIC Technologies of Switzerland; Saint Gobain Display Glass of France; Unaxis Balzers of Liechtenstein; and the Swedish LCD Center.

The Swedish LCD Center has been established as a center for education, training, prototyping, and contract small-volume production of LCDs and other FPDs, and will supply prototypes in quantities up to 1000. Among the Center's capabilities are plastic-substrate LCDs and irregularly shaped glass LCDs. (The Center has purchased a TLC Phoenix-600 curvilinear glass-cutting machine.) Said Center Director Kent Skarp, "Nobody else in



## conference report



Ken Werner

*The Ville Vielle is particularly lively on weekends. EuroDisplay registrants who walked through the Place du Palais on the Sunday before the conference began might have seen this.*

the world can supply 1000 irregularly shaped LCDs.”

Discussions are under way, said Skarp, concerning the development of roll-to-roll processing of plastic displays as part of the current EC Framework Program. The conversations will take place over the next six months, he said. If the conclusions are positive, program development will follow.

There were also booths for various European R&D programs sponsored by the EC's Framework Program, including TAKOFF (xavier.talpaert@saint-gobain.com), CANADIS (Jean-Noel.patillon@motorola.com), LCOS4LCOS (blondel@thmulti.com), PLADIS (meunierid@thmulti.com), DEPODIS (hugues.lebrun@thales.avionics-lcd.com), CROMATEAM (alain.dore@wanadoo.fr), and FLEXLED/HIGHLIGHT (aad.sempel@philips.com). The e-mail addresses in parentheses are the contact points for each program.

Unusual for a technical exhibition was the art corner, organized by Alain Doré, which was devoted to art works by Claude Massot and Zvi Yaniv. Yaniv's collaborations are static works by Yaniv and others into which

Yaniv has incorporated an LCD that displays various images. Yaniv has a long history in the U.S. display industry and is well known for his past championing of field emitters made with diamond-like films.

Massot, who is both an engineer and an artist well known in the Paris art community, creates works of art that evolve which he calls "l'Art Numérique." One very effective work was a nude in contemporary representational style that slowly evolved to become an abstraction of itself and then returned to its representational self, undergoing complex color changes along the way. These works were displayed on high-definition plasma displays.

Massot said that when he first mounted these works in brasseries in Paris, he saw that viewers were uncomfortable because the images were evolving too quickly. He experimented with slowing down the speed until the pace of change created the response he was looking for. It is important, Massot said, for people to relate to these works as quasi-static works of art that change, which is very different from their being cinema-like moving pictures.

### Poster Sessions

If the exhibition area seemed a bit underpopulated, the same could not be said for the crowded and lively Poster Session held on the opposite side of the room. Approximately 110 poster papers were presented. Among them was Valentin and Oleg Tsvetkov's prototype demonstration of a clever color-LCD technology that uses the LCD as an adjustable diffraction grating to bring the red, green, and blue peaks of the visible spectrum to the appropriate points on the display surface to serve as RGB subpixels. The system does away with the expensive matrix color filter (MCF) and produces excellent color purity and very black blacks, said Valentin Tsvetkov. The Tsvetkovs call the display a Diffraction LCD (DLCD).

Yoichi Taira and a formidable group of co-authors from IBM Research (Tokyo, Japan), International Display Technology (Yamato, Japan), and IBM T. J. Watson Research Center (Yorktown Heights, NY, U.S.A.) had another approach for doing away with the MCF. The authors commented that using a field-sequential backlight system with either CCFLs or LEDs succeeds in the elimination of the MCF and substantially increases the percentage of the light from the backlight that makes it through the display to the viewer, but this requires subframes to be updated at more than 200 Hz, which is not practical with current AMLCD technology.

Instead, the team created a static RGB backlighting system using LEDs, a total-internal-reflecting (TIR) light guide, and an array of cylindrical microlenses that direct red, green, or blue light to the appropriate subpixels. The result is a high-quality color display that triples the light-usage efficiency of traditional MCF-based LCDs and provides an improved color gamut. In the current prototype, image quality is excellent but viewing angle is limited. Taira said this problem is solvable since well-collimated light can be managed with great flexibility at the front surface.

### Special Event

We do not usually discuss the non-technical special events that are a common feature of technical conferences, but EuroDisplay's special event was, well, special: a visit to the fortified, medieval hilltop village of Eze. It was an uncommon pleasure to see members of the international display community walking through the climbing, winding, picturesque



# 18

**03**

## FEBRUARY

### 3rd International Display Manufacturing Conference & Exhibition (IDMC '03)

TAIPEI, TAIWAN  
FEBRUARY 18-21, 2003

- An international gathering of display scientists, engineers, manufacturers, marketers, integrators, users, analysts, consultants, and investors, where all aspects of display manufacturing will be discussed.
- Sponsored by the Korea Chapter of the Society for Information Display.

# SID '03

Symposium, Seminar,  
and Exhibition

Baltimore, Maryland  
Baltimore Convention Center  
May 18-23, 2003

# 15

**03**

## SEPTEMBER

### The 23rd International Display Research Conference (IDRC 2003)

PHOENIX, ARIZONA  
SEPTEMBER 15-18, 2003

- An international conference on display research and development aspects of:
- Display Materials (liquid crystals, small-molecule and polymer OLEDs, phosphors, optical compensation films, flexible substrates, etc.)
- Display modeling, Design and Processing
- Display Systems and Human Interfaces

streets of Eze – with only occasional huffing and puffing. Skillful street entertainers added to the event, and a very good outdoor buffet ended the visit on a satisfying note – all cleverly designed to encourage display-related conversations.

Another round of display-related conversations will occur at IDRC 2003, which will be held in Phoenix, Arizona, early in the autumn of 2003. More details can be found at [www.sid.org](http://www.sid.org). ■



Introducing Polar Vision's Line of Sunlight-Readable Displays

**DUPONT** Display Solutions

## For The Best View Under The Sun

Finally, there's a one-stop, global resource for all your sunlight-readable display needs.

A DuPont Displays Company, Polar Vision offers the expertise, facilities and services needed to make off-the-shelf displays brighter, clearer, – and eminently more readable under high-ambient-light conditions. Our solutions include:

- **Passive Backlight Enhancements** – which increase the light output of an LCD without increasing power consumption or heat – a crucial benefit for those applications where thermal management is of paramount importance.
- **Active Backlight Enhancements** – Our active enhancements increase brightness by adding high-output lamps. In fact, our solutions can double or triple the light output of a display.
- **Hybrid Solutions** – Featuring contrast enhancement solutions to the front - and backlight enhancements to the back – of an LCD, hybrid solutions provide the optimum balance of increased backlight luminance and improved display viewability.

So if you're in the market for the ultimate in sunlight-readable displays, give us a call at (800)269.8801, visit our web site at [www.polarvision.com](http://www.polarvision.com), or email us at [sales@polarvision.com](mailto:sales@polarvision.com). We're ready to help you get the best view under the Sun.

Polar Vision and DuPont Displays:  
The Premier One-Stop Global Resource for Display Enhancement Solutions and DuPont-Branded High Performance Displays



**POLAR VISION INC.**

A DuPont Displays Company

625 Alaska Avenue, Torrance, CA 90503 (310) 320.9768 (800) 269.8801  
FAX: (310) 320.9357 [www.polarvision.com](http://www.polarvision.com) e-mail: [sales@polarvision.com](mailto:sales@polarvision.com)

©2002 All rights reserved. POLAR VISION INC. A DUPONT DISPLAYS COMPANY.



## Baltimore, Hidden Gem of the East Coast, to Host SID 2003

*The Continental Congress met in Baltimore, and the international display community will meet there, too, from May 18 to 23, for the Society for Information Display's 34th International Symposium, Seminar, and Exhibition.*

by Ken Werner

**B**ALTIMORE is a remarkable – if sometimes under-appreciated – entertainment, scientific, technological, industrial, artistic, cultural, gastronomical, and historical center. The city sits at the head of navigation of the Patapsco River and has one of the largest harbors in the world. The river empties into Chesapeake Bay, which in the 1890s supplied 20 million bushels of oysters to much of the United States' East Coast. Today, the bay's signature seafood is the Blue Crab, and Maryland Crab Cakes are a "can't-miss" meal for Baltimore visitors. If you prefer hard-shell crabs whole, some casual restaurants will serve it with a wooden mallet.

Not everybody loved Baltimore. During the War of 1812, British merchant ships were set upon by the fast schooner-rigged Baltimore Clippers built and commissioned in the city as privateers. Britain mounted an expedition in September 1814 to root out this "nest of pirates" following its successful attack on Washington. To enter Baltimore Harbor and shell the city, the British Navy had to eliminate the batteries of Fort McHenry, which guarded the entrance to the harbor. But after 25 hours of bombardment, the fort, skillfully commanded by Major George Armistead, still stood, only slightly damaged. The British ground forces had been

blocked by a numerically superior American force and could do nothing more without the support of a naval bombardment, which would now be impossible, and the British began to withdraw.

Upon taking command of the fort more than a year before, Armistead had said, "... it is my desire to have a flag so large that the British will have no difficulty in seeing it from a distance," and a 42 x 30-ft. flag with

15 stripes and 15 stars was made. As the British withdrew, Armistead raised this flag, and *Yankee Doodle* was played.

Francis Scott Key, a Georgetown attorney who had been negotiating the release of a prisoner with the British, witnessed the battle from an American ship in the harbor. When he saw the huge American flag, he was moved to quickly write down the words of the song that would soon become known as *The Star-*



Fort McHenry saved Baltimore from sharing the fate of Washington, D.C., in the War of 1812.

*Ken Werner is Editor of Information Display; telephone 203/853-7069, fax 203/855-9769, e-mail: kwerner@sid.org.*





BACVA

*The Pride of Baltimore II is a modern wooden version of a classic Baltimore Clipper in Baltimore's Inner Harbor.*

*Spangled Banner*, along with a note that the words were to be sung to the melody of a well-known English drinking song. *The Star-Spangled Banner* became the national anthem of the United States in 1931. Today, Fort McHenry is high on the list of Baltimore tourist attractions.

Baltimore had mastered the clipper, the premier transportation technology of the first

half of the 19th century, and she was about to develop the next one: the railroad. The Baltimore and Ohio (B&O) Railroad, the first commercial railroad in the United States, was founded in 1827 to connect the mid-Atlantic region to the Ohio Valley – and thus provide competition for New York's Erie Canal. The man who wielded the spade at the groundbreaking to lay the ceremonial first stone was

the 90-year-old Charles Carroll of Carrollton, the last surviving signer of The Declaration of Independence. He was also an early investor.

The first passenger revenues were collected in January of 1830. A one-way excursion from B&O's hub at Mt. Clare to what was then the end of the line covered 1½ miles and cost 9 cents, taking six minutes in a horse-drawn car. In May, the first 13 miles of long-distance railroad in America were completed and the first regular railroad passenger service in the U.S. began. The ride from the new Mt. Clare Depot to Ellicott Mills took 90 minutes by horse-drawn car and cost 75 cents. The route crossed the new Carrollton Viaduct – the first stone railroad bridge in the United States and the oldest anywhere that is still in regular use.

The first steam locomotive built in the U.S., Peter Cooper's Tom Thumb, was built at Mt. Clare and successfully tested on B&O's tracks in August of 1830, opening the age of American steam railroading. In 1835, a 40-mile branch line was built from Mt. Clare to Washington, D.C. – the first railroad to enter the nation's capital.

In 1844, Samuel F. B. Morse had his assistant Ezra Cornell – who would later establish Cornell University – string overhead wires from the basement of the Supreme Court Building in Washington, D.C., along B&O's Washington branch line to the Mt. Clare Depot. On May 24th, Morse sent the famous first long-distance telegraph message – "What hath God wrought!" – from Washington. In the Mt. Clare Depot, the message was received by Cornell and Alfred Vail.

The B&O was one of the dominant forces in railroading for over a century. Mt. Clare, the place where American railroading started, is now the home of the B&O Railroad Museum, which has what is probably the most extensive collection of steam and diesel engines, rolling stock, railroad memorabilia, and telegraphy equipment in the country. The old depot where Cornell and Vail received Morse's message is part of the museum. On Wednesday, May 21, this beautiful and fascinating museum – the roundhouse has been called "an industrial cathedral" – will be the site of the special event at SID 2003.

But that just scratches the surface of what Baltimore can offer. The former homes of Edgar Allan Poe and Babe Ruth are now museums and are open to the public. Ruth first played professional baseball for the Balti-



## visiting Baltimore



The Iron Horse Wins, by Carl Rakeman. Actually, the rail car pulled by the flesh-and-blood horse won the race near Baltimore on August 28, 1830, when a blower belt broke in Peter Cooper's locomotive Tom Thumb. But Tom Thumb had led the race, doing 15 miles per hour around the curves, and it proved the feasibility of steam traction. All horses on the B&O Railroad were replaced by steam locomotives on July 31, 1831. (Courtesy of the Federal Highway Administration, U.S. Department of Transportation.)

more Orioles, then a minor-league team. His home is just two blocks from Oriole Park at Camden Yards, widely regarded as the most beautiful of modern baseball parks, in part because it takes its architectural inspiration from classic ballparks of the 1920s. The Orioles will be playing home games at Camden Yards May 16–18 (against the Tampa Bay Devil Rays) at the beginning of Display Week.

Baltimore's Inner Harbor has been turned into a waterside promenade that is hugely popular with both residents and tourists. In addition to restaurants and extensive food courts, Baltimore's maritime and industrial history finds a home here. Among the attractions are

- The USS *Constellation*, the last all-sail warship built by the U.S. Navy (in 1854).
- The *Pride of Baltimore II*, a modern wooden Baltimore Clipper that follows the classic designs of the early 1800s.
- The USCGC (United States Coast Guard Cutter) *Taney*, the last surviving warship that fought during the attack on Pearl Harbor, December 7, 1941.

- The harbor inspection tug *Baltimore*, built in 1906, is the oldest operating steam-powered coal-fired tugboat in the United States.
- The USS *Torsk*, the submarine that accounted for the last ship sunk in World War II, and which participated 17 years later in the blockade of Cuba during the Cuban Missile Crisis.

For those who appreciate interesting and significant architecture, Baltimore has an unfair share of it, including the Old Roman Catholic Cathedral – the oldest Catholic cathedral in the U.S. – designed by Benjamin Henry Latrobe, who also designed the U.S. Capitol. The cathedral is considered his masterpiece.

Don't forget a visit to the Fells Point Historic District. More than 800 ships were built at Fells Point shipyards between 1784 and 1821, including the original *Constellation* in 1797 and many Baltimore Clippers. Seamen and sailmakers lived in the many small two-story houses, which are rapidly being gentrified. Any worthwhile harbor settlement is

well supplied with eating and drinking establishments, and this tradition is carried on at Fells Point with enthusiasm.

The Walters Art Museum has an extensive collection; it encourages one to come and experience 55 centuries of art. Among its collections are 1000 pieces of Asian art, including the oldest surviving wooden image of the Buddha.

If there's time for wandering, visit the charming small city of Annapolis. In addition to being a maritime community, the home of the U.S. Naval Academy, and a bastion of small antique shops, it is the capital of Maryland.

The Eastern Shore is that part of Maryland on the eastern side of Chesapeake Bay, a relatively easygoing place devoted to farming, fishing, and summer homes. It is also where "oysters" is pronounced "arsters." There should be good fishing and sailing on the Chesapeake in May and plenty of Marylanders happy to charter or rent boats to display people who are ready to relax after Display Week. Maybe a couple of days in a Bed & Breakfast would do the trick, with plenty of crabs and arsters for dinner. ■

15 <sup>03</sup>

SEPTEMBER

The 23rd International Display Research Conference (IDRC 2003)

PHOENIX, ARIZONA  
SEPTEMBER 15–18, 2003

- An international conference on display research and development aspects of:
  - Display Materials (liquid crystals, small-molecule and polymer OLEDs, phosphors, optical compensation films, flexible substrates, etc.)
  - Display modeling, Design and Processing
  - Display Systems and Human Interfaces



continued from page 2

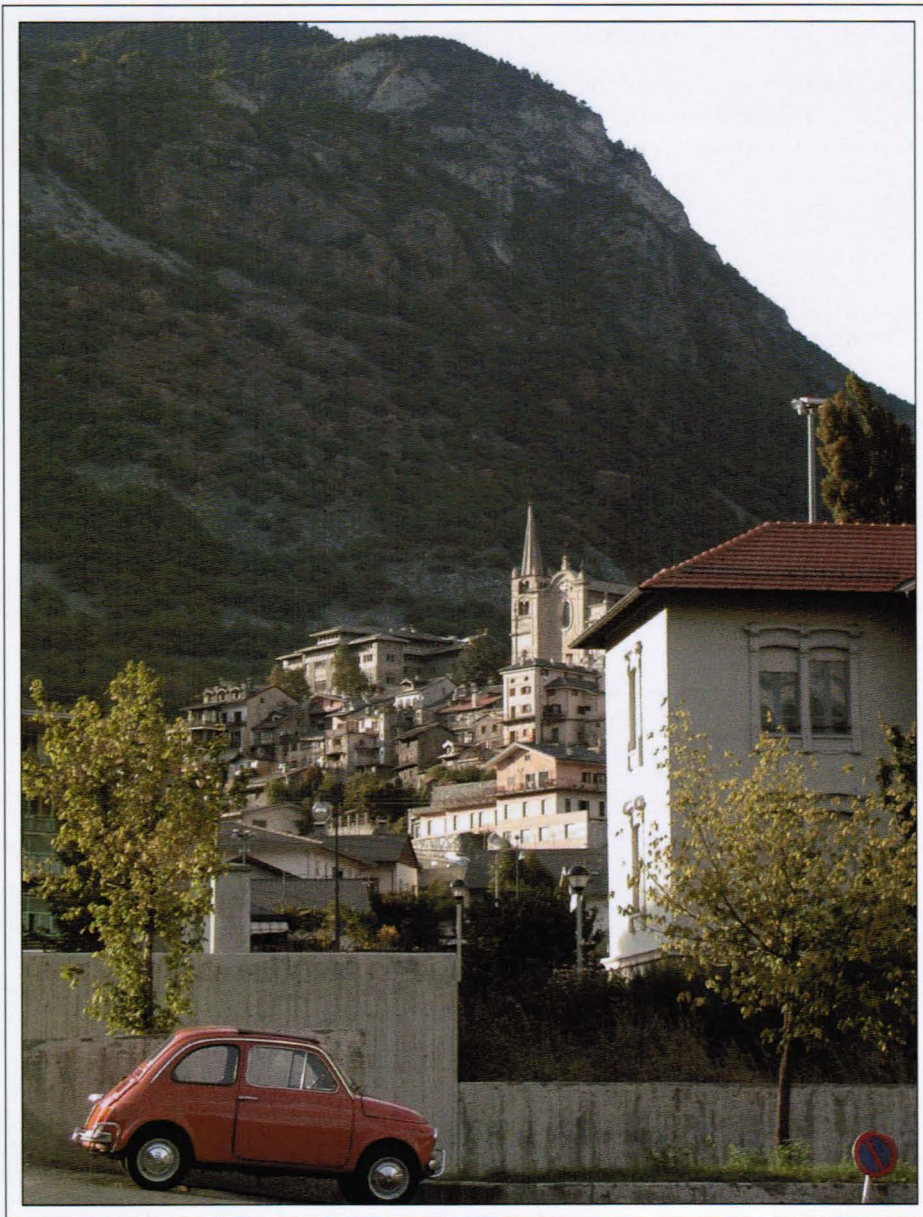

Ken Werner

*The pleasing village of Chatillon can be seen on the left of the entrance to Tecdis.*

But the corporate strategies of Seiko and Olivetti were changing, and Morezzi helped move the company into private ownership in 1994 via a management buyout. Seiko remains a partner and distributes Tecdis displays in the U.S. and Germany under the Seiko name.

In 1999, Tecdis acquired the LCD-maker DICRYL, located in Valladolid, Spain. DICRYL has been completely integrated into Tecdis and is now called Tecdis Iberica. Both

plants are certified to ISO 9002 and ISO 14001, and will be certified to Vision 2000 (an update of 14001) in 2003. QS9000 certification (for automotive applications) will follow in 2004.

The company has 600 employees, 77% of which are in manufacturing, and revenues in 2001 were €75 million. It specializes in small displays for cellular phones, white goods (kitchen and other domestic appliances), and digital electrical meters (which are replacing

electromechanical meters in Europe to permit remote reading). The automotive market will be an important one for Tecdis, Morezzi said.

In Chatillon, Tecdis uses the same in-line manufacturing plant that was installed in 1990. As refined and updated over the years, it has a glass capacity of 100,000 m<sup>2</sup> and produces a yield of 99.5%. The plant has a chip-on-glass (COG) bonding capacity of 20 million pieces per year. At the time of my visit, the company was just producing the first samples of a new product: a 120 × 160 transflective 2-in. color STN-LCD with multi-line addressing (MLA), COG and COF drivers, and an LED backlight.

Morezzi said it is clear that Tecdis cannot beat the big Asian manufacturers at their own game, and it would be foolish to try. But he also rejected the idea that all display intelligence resides in Japan. "We cannot compete directly, so we must be innovative and imaginative." Morezzi recognizes the sheer size of Asian LCD manufacturers contains vulnerability as well as great strengths. A smaller company is better able to experiment with non-traditional processes than a very large one, and is in a better position to implement those new processes across the product line when they are successful.

This is the kind of thing senior executives are likely to say, but Tecdis is aggressively implementing the strategy with four major programs:

1. The company has licensed Optiva's technology for coatable self-assembling molecular polarizers called Thin Crystal Film (TCF<sup>™</sup>) and is developing processes for using these materials in a mass-production environment. One advantage of the Optiva material is that it can be coated on the insides of the LCD plates, creating an LCD that is very rugged and extremely resistant to scratches. Another advantage is that it will allow Tecdis to avoid the "monopoly pricing" of the major purveyors of conventional polarizing films.
2. Tecdis has licensed Nemoptic's BiNem<sup>™</sup> technology for making high-contrast bistable displays with conventional nematic LC materials. I was shown sample displays with very dark blacks and impressive contrast.
3. The company is developing plastic-substrate technology with an Italian partner.





Ken Werner

*A steep mountain with a 15th-century castle can be seen on the right of the entrance to Tecdis.*

4. Tecdis has created a joint venture with STMicroelectronics called Dora to design and manufacture specialized driver chips for telecom and automotive LCDs, with an emphasis on COG. The joint venture will sell chips on the open market, with Tecdis as an enthusiastic customer.

The "holy grail" toward which Tecdis is working, said Morezzi, is a color quarter-VGA BiNem™ LCD with TCF™ polarizers and all electronics in four COG Dora chips, *i.e.*, a display that could have enough performance and cost benefits to be highly competitive in Tecdis's mostly custom markets.

I left Chatillon impressed with the people and strategy of Tecdis. It is the last volume manufacturer of LCDs left standing in Europe, and its people have a plan.

— KIW

We welcome your comments and suggestions. You can reach me by e-mail at [kwerner@nutmegconsultants.com](mailto:kwerner@nutmegconsultants.com), by fax at 203/855-9769, or by phone at 203/853-7069. The contents of upcoming issues of *ID* are available on the *ID* page at the SID Web site (<http://www.sid.org>).

# SID '03

## Baltimore, Maryland

### Baltimore Convention Center

#### May 18–23, 2003

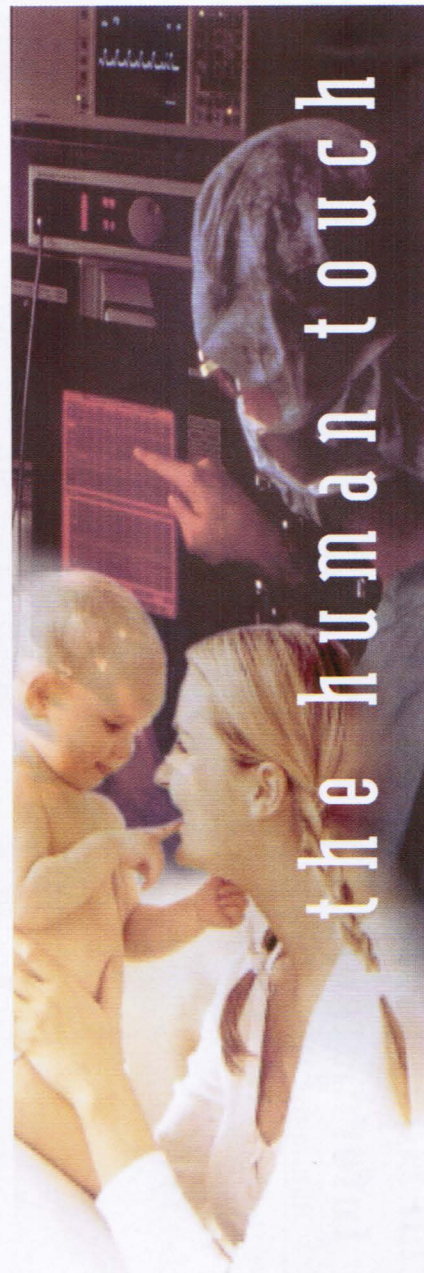

**CyberTouch** designs and manufactures specialty touch screens for the medical, industrial, military and aerospace industries.

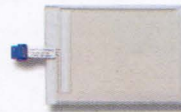

Select from a wide range of off-the-shelf touch screens or have us custom design one for you.

Get in touch with CyberTouch!



**CyberTouch**

805.499.5000 • 800.958.4321  
[cybertouch.com](http://cybertouch.com)





# Official Housing Request Form: Society for Information Display (SID-2003)



Baltimore, MD - May 18-23, 2003

The official housing closing date is April 14, 2003. If you have not made reservations by this date, contact Globetrotter Travel, and every effort will be made to secure accommodations for you.

**Fill out this form completely and mail or fax to:**

**Globetrotter Travel**  
18121 Georgia Avenue  
Suite 104  
Olney, MD 20832  
Fax: 301-570-9514

**No Reservations Will Be Taken By Phone  
For Housing Information Only Call:**

301-570-0800 (Press 2)

**ON-LINE RESERVATIONS:**

<http://www.globetrottermgmt.com/sid>

Save up to 15% on Published Air Fares.

Call 301-570-0800 (Press 1)

E-Mail us at [sid@globetrottermgmt.com](mailto:sid@globetrottermgmt.com)

Hotel	Distance from Event	Single Rate	Double Rate	Triple Rate	Quad Rate
1 Renaissance (Headquarter Hotel)	3 Blocks	\$192	\$192	\$192	\$192
2 Holiday Inn	1 Block	\$159	\$159	\$169	\$169
3 Hyatt Regency	1 Block	\$199	\$219	\$239	\$259
4 Marriott Inner Harbor	2 Blocks	\$177	\$197	\$217	\$237
5 Marriott Waterfront	9 Blocks	\$193	\$193	\$218	\$243
6 Radisson Plaza	3 Blocks	\$179	\$179	\$199	\$219
7 Wyndham	3 Blocks	\$172	\$172	\$192	\$212

All reservations are on a first come first served basis. Globetrotter will acknowledge the reservation within 5-7 business days for forms faxed or mailed. Acknowledgment is automatically generated for on-line bookings. You will receive confirmation directly from your hotel approximately 2-3 weeks prior to the convention. If you have any special requests, please list them here: \_\_\_\_\_

\_\_\_\_\_

\_\_\_\_\_

**Contact Information:**

Name: \_\_\_\_\_

Address: \_\_\_\_\_

City \_\_\_\_\_ St \_\_\_\_\_ ZIP \_\_\_\_\_

Country \_\_\_\_\_

Phone: \_\_\_\_\_

Fax: \_\_\_\_\_

E-Mail \_\_\_\_\_

Please Check One of the Categories Below:

- Attendee
- Exhibitor

**Hotel Choices:** 1) \_\_\_\_\_ 2) \_\_\_\_\_ 3) \_\_\_\_\_ 4) \_\_\_\_\_  
**Occupant Information:** (Each line represents 1 room unless otherwise specified)

Smoking Y/N	Number of People	Number of Beds	Name(s) of Occupant(s)	Arrival Date	Departure Date

All reservations require a deposit of the first night with a credit card number or check made payable to Globetrotter Travel in US funds.

**Credit Card Number:** \_\_\_\_\_ **Exp Date:** \_\_\_\_\_

**Cardholder's Name:** \_\_\_\_\_

**Cardholder's Signature:** \_\_\_\_\_

**Check Enclosed:** \_\_\_\_\_



**Society for Information Display  
SID-2003 - Baltimore, Maryland  
Baltimore Hotel Map**

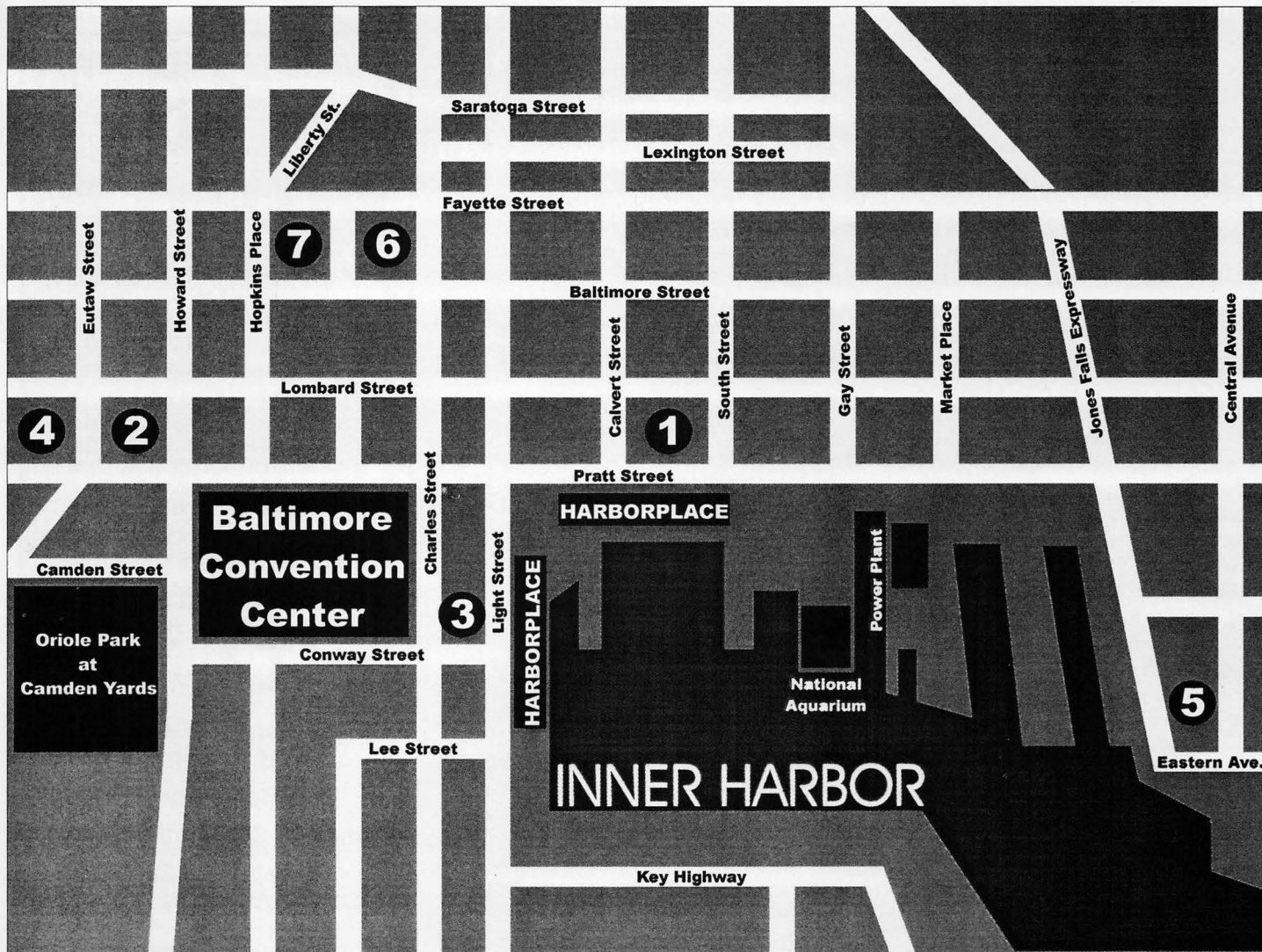

- ① Renaissance (Headquarter Hotel)**
- ② Holiday Inn**
- ③ Hyatt Regency**
- ④ Marriott Inner Harbor**
- ⑤ Marriott Waterfront**
- ⑥ Radisson Plaza**
- ⑦ Wyndham**



**GLOBETROTTER**  
*We think of everything.™*



## my turn

continued from page 4

- JC Decaux, Solari, and others are active suppliers of variable-message signs installed on roads and in the cities.
- Barco and Synelec are leaders in display projectors and display walls for supervision, control, and TV entertainment.

In addition to all of the industrial activities listed above, some companies like ROLIC and Nemoptic – with their original LCD processes – and the Swedish LCD Center AB demonstrate that new technology developments and design services are also a part of Europe's many display activities.

These activities, which were just hinted at by the lengthy list just presented, are perhaps less spectacular than the demonstration of a 40-in. TFT-LCD or an 80-in. plasma display, but they are profitable endeavors, resulting, at least in part, from 20 years of European R&D cooperation promoted by European Commission policy.

EuroDisplay 2002 was held in the very large Nice Acropolis Center, where attendees observed many examples of modern art. The entrance of the exhibit hall, with four digital-art dynamic pictures integrating TFT-LCDs and plasma displays, was very much in keeping with this environment.

The visit to the medieval city of Eze – the EuroDisplay 2002 social event – reminded me that during the Middle Ages, basic educational information was displayed by the stained-glass windows of the Roman Churches, the ancestors of our modern displays. News was transmitted by the “saltimbanques,” who were not merely circus performers, just as our TV channels today broadcast both news and entertainment programs.

Because good sound improves the perception of image quality, I dream – after visiting the Fragonard perfumery at Eze – that in the future our electronic displays will be able to reproduce not only good images with complex sounds, but also the accompanying scents and flavors! That should be an entertaining challenge for our R&D teams. ■

**Alain Doré** is President of Le Club Visu – SID-France and was Chair of the EuroDisplay 2002 Steering Committee.

## backlight

continued from page 48

Or consider the wide-screen HDTV alternatives. A 34-in. Sony or Panasonic CRT-based offering about 23 in. deep, at \$2499, comes in at \$500 less than a much smaller 22-in. Panasonic LCD-based TV at \$2999 with a depth of 9.5 in. This comparison reduces the dollars for saved depth to under \$40 an inch but at a cost of 12 in. of diagonal screen size. Only, I think, where real estate is extremely precious would the average consumer willingly accept such a tradeoff, which is an even greater issue among very large TV screens, where the PDP confronts the CRT and rear-projection TV.

So it appears that this consumer is not about to buy a hang-on-the-wall TV or, for that matter, any HDTV or large-screen TV at all, FPD-based or otherwise. (Nor am I about to give up my vinyl or, for that matter, my VHS tapes.) I do, however, know one couple that recently went shopping for a leading-edge TV, and they came home with a big CRT. A pretty savvy pair, they made their ultimate decision based not on price but on image quality, although I am sure the price tag of the PDP TV they looked at was a significant disincentive. “We didn’t like the colors [of the PDP screen],” I was told. Consumers are quirky.

As for the LCD vs. CRT competition in the computer-monitor space, you can call this consumer an anti-Luddite. With monitors, I don’t see the same kind of situation that I see in TVs. Perhaps it’s because I am a convinced believer in the preciousness of desktop real estate. And perhaps the pricing differential does not carry the same weight for all products and across all pricing levels.

A local office-supply store named Staples is having a special sale on a 17-in. (16-in. viewable) CRT monitor and a 15-in. LCD monitor with the same XGA format, normally priced at about \$180 and \$450, respectively. Frankly, if I needed a monitor before the sale, I wouldn’t buy either one of these. The reason is that I am not willing to put up with the depth of a big CRT, and \$450 for an LCD – two-and-a-half times the price of the CRT – is more than I want to spend. With the sale, though, the CRT has been reduced by \$100 to \$80 and the LCD by \$150 to \$300. Call me quirky if you like, but I would buy the LCD if I were in the market for a monitor, although the price differential has increased to almost 4:1! ■

**David Lieberman** is a veteran display journalist living in Massachusetts.

# 18<sup>03</sup>

## FEBRUARY

### 3rd International Display Manufacturing Conference & Exhibition (IDMC '03)

TAIPEI, TAIWAN  
FEBRUARY 18–21, 2003

- An international gathering of display scientists, engineers, manufacturers, marketers, integrators, users, analysts, consultants, and investors, where all aspects of display manufacturing will be discussed.
- Sponsored by the Korea Chapter of the Society for Information Display.

# SID '03

## Symposium, Seminar, and Exhibition

Baltimore, Maryland

Baltimore Convention Center

May 18–23, 2003

# 15<sup>03</sup>

## SEPTEMBER

### The 23rd International Display Research Conference (IDRC 2003)

PHOENIX, ARIZONA  
SEPTEMBER 15–18, 2003

- An international conference on display research and development aspects of:
  - Display Materials (liquid crystals, small-molecule and polymer OLEDs, phosphors, optical compensation films, flexible substrates, etc.)
  - Display modeling, Design and Processing
  - Display Systems and Human Interfaces



## sustaining members

Acheson Industries, Inc.  
 Ad-Vance Magnetics, Inc.  
 Advance Reproduction Corp.  
 Aerospace Display Systems  
 AMJ Industries, L.L.C.  
 Amulet Technologies  
 Applied Concepts  
 ATI Technologies, Inc.  
 AU Optronics Corp.  
 autronic - Melchers GmbH  
 Brewer Science, Inc.  
 Brimar Ltd.  
 Candela Instruments  
 Cando Corp.  
 Canon, Inc.  
 CELCO  
 The Cherry Corporation  
 Chi Mei Optoelectronics Corp.  
 Chungwa Picture Tubes, Ltd.  
 Ciba Specialty Chemicals  
 ClairVoyante Laboratories, Inc.  
 Clinton Electronics Corp.  
 Corning Incorporated  
 Corning Japan K.K.  
 CYRO Industries  
 Data International  
 Delphi Automotive Systems Singapore  
 DisplaySearch  
 Dontech, Inc.  
 DuPont Displays  
 E-Ink Corp.  
 ELDEC Corp.  
 Electro-Plasma, Inc.  
 Endicott Research Group  
 ERSO/ITRI  
 Firan Technology Group  
 Futaba Corp. R&D Center  
 GDS  
 Gebr. Schmid GmbH & Co.  
 Gennum Corp.  
 GPO Corp.  
 Hannstar  
 Hitachi, Ltd.  
 Hoya Corp., USA  
 Hunet, Inc.  
 iFire Technology  
 IMT Masken und Teilungen AG  
 Incom, Inc.  
 Industrial Electronic Engineers, Inc.  
 Info Incorporation  
 Innova Electronics, Inc.  
 Instrument Systems  
 Integrated Technology Express, Inc.  
 Interface Display & Controls, Inc.  
 Intevac, Inc.  
 iSupply/Stanford Resources  
 Japan Patent Office  
 Kent Displays  
 LCD Lighting, Inc.  
 Lexel Imaging Systems, Inc.  
 LG.Philips LCD  
 Lite Array, Inc.  
 Micronic Laser Systems AB  
 Microvision, Inc.  
 Mitsubishi Electric Corp.  
 Myson Century, Inc.  
 National Semiconductor Corp.  
 NEC Corp.  
 Nippon Seiki Co., Ltd.  
 Noritake Itron Corp.  
 OCLI — A JDS Uniphase Company  
 OES/ITRI  
 Optrex America  
 OSRAM GmbH  
 Phosphor Technology Ltd.  
 Photon Dynamics  
 Photo Research  
 Pioneer Electronics (USA), Inc.  
 Planar Systems  
 Plasmaco, Inc.  
 Polar Vision, Inc.  
 Polytronix, Inc.  
 Quanta Display, Inc.  
 Quantum Data Inc.  
 Reflexite Display Optics  
 ROLIC Research Ltd.  
 ROLIC Technologies, Ltd.  
 Sarnoff Corp.  
 Schott Corp.  
 Sharp Corp.  
 SI Diamond Technology  
 Silicon Optix, Inc.  
 Silver Cloud Manufacturing Co.  
 Sony Chemicals Corp. of America  
 Sony Corp. Research Center  
 Supertex, Inc.  
 Symbol Technologies, Inc.  
 Tannas Electronics  
 Thomas Electronics, Inc.  
 Three-Five Systems, Inc.  
 Tiun Yuan Technology Co., Ltd.  
 TLC International  
 Toppoly Optoelectronics Corp.  
 Toshiba America Electronic  
 Components, Inc.  
 Unaxis Balzars, Ltd.  
 UNIGRAF  
 Universal Display Corp.  
 Video Electronics Standards  
 Association  
 Viratec Thin Films, Inc.  
 Vishay-Dale Electronics, Inc.  
 VON ARDENNE Coating Technology  
 Westar Corp.  
 WINTEK Corp.  
 ZBD Displays, Ltd.

## index to advertisers

Astro Systems .....6  
 Bi-Search International.....8  
 CyberTouch .....43  
 DisplaySearch.....23  
 Elo Touch Systems .....10  
 Eyesaver International .....18  
 Horizon Technology .....C2  
 Microvision.....39  
 Photo Research .....19  
 Polar Vision .....35  
 Quantum Data.....5  
 Radiant Imaging .....9  
 Society for Information Display .....40,41  
 Tempo Plastic .....41  
 3M Optical Systems.....7,C3  
 Unigraf.....39  
 VESA .....3,C4  
 Westar Display Technologies.....11

### Business and Editorial Offices

Palisades Convention Management  
 411 Lafayette Street, 2nd Floor  
 New York, NY 10003  
 Jay Morreale, Managing Editor  
 212/460-8090 x212 Fax: 212/460-5460  
 jmorreale@pcm411.com

### Sales Office - Europe

George Isaacs  
 12 Park View Court  
 The Paddock, Eaton Ford  
 St. Neots, Cambridgeshire  
 PE19 7SD U.K.  
 Phone/Fax: +44-(0)-1480-218400  
 george@gandg.demon.co.uk

### Sales Office - Japan

Ted Asoshina  
 General Manager  
 Echo Japan Corp.  
 Grande Maison Room 303  
 2-2, Kudan-Kita 1-chome  
 Chiyoda-ku, Tokyo 102-0073 Japan  
 +81-3-3263-5065  
 Fax: +81-3-3234-2064  
 echoj@bonanet.or.jp

### Sales Office - U.S.A.

Palisades Convention Management  
 411 Lafayette Street, 2nd Floor  
 New York, NY 10003  
 Joanne Morgenthal, Sales Manager  
 212/460-8090 x211 Fax: 212/460-5460  
 jmorgenthal@pcm411.com

### Sales Office - Korea

Jung-Won Suh  
 Sinsegi Media, Inc.  
 Masters Tower, Room 2410  
 553, Dowha-dong  
 Mapo-ku, Seoul 121-040 Korea  
 +82-2-313-1951/2 Fax: +82-2-312-7335  
 sinsegi@sinsegi-media.info

### Sales Office - Taiwan

Michael Young  
 Trade Media Representative, Inc.  
 3F, No. 140, San Min Rd.  
 Taipei, Taiwan, R.O.C.  
 +886-2-2763-2438  
 Fax: +886-2-2545-7868  
 mediarep@seed.net.tw





## Call Me Quirky

by David Lieberman

Call me a Luddite if you like because I do not yet have an HDTV hanging on my wall, but I think I am a typical consumer with my own personal set of quirks. However, I recently received something in the mail that made me consider big-screen TVs, although I am still skeptical. But if I ever do get one, I want the very magical kind that you see on TV commercials and in magazine ads: the ones that have neither a power cord nor a cable or antenna hookup. About ten years ago, I borrowed a mail-order catalog of an audio supply house named Crutchfield from a friend to look for a replacement turntable for my stereo system. You see, I am not one of those who quickly jump on the latest consumer-electronics bandwagon, nor do I relish the thought of replacing a collection I already have on one medium with the same collection on a new medium, whether it is music, movies, or whatever. And it seems that the march of technology had passed me by, along with all the other vinylphiles in the world, because I couldn't find a turntable anywhere in my search through at least three different shopping malls in Massachusetts and New Hampshire. The catalog I borrowed, however, did have a selection of turntables, although it was an abysmally small one, and I was able to get what I needed by mail order.

I have now been getting that catalog quarterly for the past decade, though I haven't ordered anything besides the turntable during that time. A new copy appears in my mailbox like clockwork year after year after year, and it immediately goes into a recycling bin. But I saved the latest version because of my interest in flat-panel displays. The product featured on the cover was an LCD TV.

The television section of Crutchfield's Fall 2002/Winter 2003 audio/video catalog contains a mere six pages at the end of a 149-page compilation, complete with a matrix table of the characteristics of 35 models. These included 15- and 22-in. (diagonal) wide-screen (16:9 aspect ratio) LCD TVs plus a wide-screen 15.2-in. LCD TV with a built-in DVD from Panasonic; 13-, 15-, and 20-in. LCD TVs from Sharp; and wide-screen 15- and 17-in. LCD TVs with PC compatibility from Samsung. The chart also refers shoppers to Crutchfield's Web site for details on a wide-screen 30-in. Sharp LCD TV.

So much for FPD-based TVs. The remainder of the televisions consisted of seven rear-projection CRT TVs from JVC and Sony measuring between 43 and 65 in. on the diagonal and 19 direct-view CRT TVs from JVC, Panasonic, Samsung, and Sony measuring between 20 and 40 in. Not a single instance of a PDP TV, with its astronomical price tag, appears in the catalog. Nor is there a single microdisplay-based rear-projection TV in the mix.

I would guess that Crutchfield will do far more TV business in CRTs than in LCDs, considering the price issue alone. The price tag of even a premium CRT-based TV such as Sony's 20-in. FD Trinitron Wega is around \$350, pretty high by CRT TV standards, but minuscule compared to that of an LCD TV. Sharp's 20-in. LCD offering comes in at about \$2000, almost six times the price of the Sony TV. True, it is only 2.25 in. deep, compared with 20.5 in. for the Sony, but that means the depth saved by the FPD TV is extraordinarily expensive, costing roughly \$90 per linear inch in this comparison.

*continued on page 46*

**The Third International Display Manufacturing Conference & Exhibition 2003.** Contact: SID HQ, Dee Dumont, 408/977-1013, fax -1531, e-mail: office@sid.org.

**February 19-21, 2003 Taipei, Taiwan**

**FPD Expo Taiwan 2003.** Contact: Sue Chung, 408/943-7961, e-mail: schung@semi.org.

**February 19-21, 2003 Taipei, Taiwan**

**SID 2003 International Symposium, Seminar, and Exhibition (SID '03).** Contact: SID HQ, Dee Dumont, 408/977-1013, fax -1531, e-mail: office@sid.org, www.sid.org.

**May 18-23, 2003 Baltimore, Maryland**

**The 8th Asian Symposium on Information Display (ASID '03).** Contact: Southeast University, Electronic Engineering Dept., Nanjing, Jiangsu, 210018 China, telephone/fax +86-25-3363222, URL: www.asid03.seu.edu.cn.

**August 17-20, 2003 Nanjing, China**

**The 23rd International Display Research Conference (IDRC '03).** Contact: SID HQ, Dee Dumont, 408/977-1013, fax -1531, e-mail: office@sid.org.

**September 15-18, 2003 Phoenix, AZ ■**

*Please send new product releases or news items to Information Display, c/o Palisades Convention Management, 411 Lafayette Street, 2nd Floor, New York, NY 10003.*

15 <sup>03</sup>

SEPTEMBER

*The 23rd International Display Research Conference (IDRC 2003)*

PHOENIX, ARIZONA  
SEPTEMBER 15-18, 2003

• An international conference on display research and development aspects of:  
• Display Materials (liquid crystals, small-molecule and polymer OLEDs, phosphors, optical compensation films, flexible substrates, etc.) • Display modeling, Design and Processing • Display Systems and Human Interfaces



# Guarantee your competitive edge.



## Current Committees

Display  
Display Metrology  
Digital Packet Video Link  
Japan  
Microdisplay

VESA Committees are currently creating standards that will cover several areas, including: advanced and packetized video interfaces, multi-display, mobile digital display, flat display mounting interfaces and Plug and Play enhancements.

Be there at the beginning. Participate in the development of ground-breaking display industry standards with VESA's (Video Electronic Standards Association) international team of industry experts.

## First ones to know

Join over 120 member companies from around the world who already benefit from advanced knowledge of new technology standards.

As a member, you are invited to take part in monthly committee and workgroup meetings, or simply be the first to access resulting technical papers and industry standards.

## Display industry leaders

Steadfastly dedicated to innovation and market growth, VESA members lead through their visionary efforts to develop and promote open standards.



# VESA

See our virtual trade show at [VESA.org](http://VESA.org)